

**Series 8009
9-Meter Earth Station Antenna**

Installation, Operation and Maintenance Manual

**Manual Part No. 42S315F
February 2004**

Notice

All Rights Reserved

The information contained in this document is proprietary to ViaSat, Inc. This document may not be reproduced or distributed in any form without the consent of ViaSat, Inc.

The information in this document is subject to change without notice. ViaSat, Inc. assumes no responsibility for any errors that may appear in this document and does not warranty any specific application.

Any product names mentioned herein are used for identification purposes only, and may be trademarks and/or registered trademarks of their respective companies.

In all correspondence with ViaSat, Inc. regarding this publication, please refer to the Manual Part No. on the title page.

Copyright © 2003, 2004 ViaSat, Inc.

All rights reserved. No part of this book may be reproduced in any form or by any means without permission in writing from ViaSat, Inc.

TABLE OF CONTENTS

Table of Contents	iii
List of Figures	v
List of Tables	v
Safety Summary	vi
1 General Information	1-1
1.1 Introduction.....	1-1
1.2 Mount Description	1-1
1.3 Reflector Description.....	1-6
2 Installation.....	2-1
2.1 Introduction.....	2-1
2.1 Unpacking and Inspection	2-1
2.1.1 Damage or Loss During Shipment.....	2-1
2.1.2 What to do about Visible Loss or Damage	2-1
2.1.3 What to do about Concealed Damage.....	2-1
2.2 Equipment Return	2-2
2.3 Safety	2-3
2.3.1 Emergency Plan	2-3
2.3.2 General Mechanical Safety	2-3
2.3.3 General Electrical Safety Summary.....	2-4
2.3.4 Resuscitation	2-4
2.4 System Assembly.....	2-5
2.4.1 Site Preparation.....	2-5
2.4.2 Recommended Tools and Equipment	2-5
2.4.3 Fastener Information.....	2-7
2.4.4 Recommended Sequence of Assembly.....	2-8
2.4.5 Preparation for Assembly	2-8
2.4.6 Assembly of Reflector, Spars and Subreflector	2-9
2.4.7 Mount Installation.....	2-20

2.4.8	Grouting Baseplate to Foundation, Models 8009A and 8009AE	2-30
2.4.9	Reflector Mounting	2-33
2.4.10	Optional Lightning Protection Installation.....	2-38
2.4.11	Optional Deicing Installation.....	2-39
2.4.12	Electrical Installation.....	2-39
2.4.13	Corrosion Protection	2-39
3	Operation.....	3-1
3.1	General.....	3-1
3.2	Satellite Pointing Procedure.....	3-1
3.2.1	Elevation Pointing	3-1
3.2.2	Azimuth Pointing	3-1
3.2.3	Signal Peaking Procedure.....	3-2
3.3	Subreflector Adjustment.....	3-3
4	Maintenance	4-1
4.1	General.....	4-1
4.2	Periodic Maintenance	4-1
4.2.1	Weekly Maintenance.....	4-1
4.2.2	Monthly Maintenance.....	4-1
4.2.3	Bi-Monthly Maintenance.....	4-2
4.2.4	Quarterly Maintenance.....	4-2
4.2.5	Yearly Maintenance.....	4-5
4.3	Corrosion Protection	4-6
4.3.1	Touch-up Painting of Non-Reflective Surfaces	4-6
4.3.2	Touch-Up Painting of Reflective Surfaces	4-7
4.3.3	Fasteners	4-8
5	Drawings	5-1
5.1	Introduction.....	5-1
5.2	Drawing Index	5-1
5.3	Parts Lists.....	5-1

LIST OF FIGURES

Figure 1-1. Typical Antenna System.....	1-2
Figure 1-2. Elevation and Azimuth Angle Stow Chart for High Wind Conditions	1-4
Figure 2-1. 9-Meter Antenna Reflector and Subreflector Alignment.....	2-18
Figure 2-2 Installing Leveling Nuts.....	2-21
Figure 2-3 Rigging Lifting Points.....	2-25
Figure 2-4 Rigging Lifting Points.....	2-28
Figure 2-5. Hoisting Reflector and Spars	2-34
Figure 2-6. Hoisting Feed.....	2-36
Figure 3-1. Feed, Reflector, and Subreflector Distances	3-3
Figure 3-2. Typical Antenna Patterns for Various Subreflector Position	3-6
Figure 4-1. Lubrication Points (Sheet 1 of 2)	4-4

LIST OF TABLES

Table 1-1. Antenna Mount Configurations.....	1-1
Table 2-1. Tools and Equipment Required For Installation	2-5
Table 2-2. Torque Values For Antenna Fasteners.....	2-7
Table 2-3. Panel Rough Alignment.....	2-15
Table 2-4. Final Alignment Target Measurements - Sight Center of the Middle Diamond	2-17
Table 2-5. 9-Meter Reflector Alignment Record	2-19
Table 4-1. Torque Values For Antenna Fasteners.....	4-10
Table 5-1. Drawing Index.....	5-1

SAFETY SUMMARY

Notice

Any service, adjustment, maintenance, or repair of this product must be performed only by authorized technical service personnel.

Prior to installation and use of this product review all safety markings and instructions. When safety precautions or important information is presented in this manual, the information will normally be presented just prior to the point where the hazard is likely to be encountered.

The following symbols are used throughout this manual to bring attention to practices, procedures, and conditions important to the safety of the operator and equipment or to obtaining desirable results from the equipment.



WARNING

This symbol warns of electrical shock hazards to personnel. Failure to comply with the instructions of such a warning may result in severe injury or death resulting from electrical shock.



WARNING

This symbol warns of non-electrical hazards to personnel. Failure to comply with the instructions of such a warning may result in severe injury or death.



CAUTION

This symbol warns of hazards to equipment. Failure to comply with the instructions of such a caution may result in damage or destruction of equipment.



GROUNDING REQUIRED

This symbol is used to bring attention to installation grounding requirements.

NOTE

Notes are used to provide clarification, or to alert the reader of possible erroneous results, which may occur if a procedure is not followed as written.

Chapter 1

General Information

1.1 Introduction

This manual contains information needed to properly install, operate, and maintain the Series 8009A 9-Meter Earth Station Antenna which provides high quality receive/transmit and receive-only capabilities for both domestic and international C-band or Ku-band applications. The antenna consists of a 9-meter shaped reflector, a shaped subreflector, and a linear or circular polarized feed on a high-strength structural steel elevation-over-azimuth mount.

This chapter of the manual contains general descriptions and specifications on the mount, reflector, feed, and subreflector. Chapters 2 through 5 contain information pertaining to antenna installation, operation, and maintenance.

1.2 Mount Description

The 9-Meter reflector can use any of three mounts, the Model 8009A (120°), the Model 8009AE (120°) and the Model 8009AE (180°) mounts. The mount configurations are described in Table 1-1. See Figure 1-1 for a typical antenna system.

Table 1-1. Antenna Mount Configurations	
Mount Description	Required Components
Model 8009A (120°) Provides 160° total azimuth coverage, in three overlapping 120° sectors	Model 8009A (120°) foundation Model 8009A 15 ton elevation actuator Model 8009A 20 ton azimuth actuator
Model 8009AE (120°) Provides 180° total azimuth coverage, in three overlapping 120° sectors	Model 8009AE (120°) foundation Model 8009AE 30 ton elevation actuator Model 8009AE 30 ton azimuth actuator
Model 8009AE (180°) Provides 180° continuous azimuth coverage	Model 8009AE (180°) foundation Model 8009AE 30 ton elevation actuator Model 8009AE 30 ton azimuth actuator

The Series 8009A antenna mounts provide two-axis (elevation-over-azimuth) adjustment for pointing the antenna. In the elevation-over-azimuth configuration, the antenna rotates about two axes, a vertical azimuth axis and a horizontal elevation axis. Pointing to a geostationary satellite requires that the antenna be moved to a specific angle about the azimuth axis, then to a specific angle about the elevation axis. The required sighting angles for any satellite are given in look-up tables which are readily available.

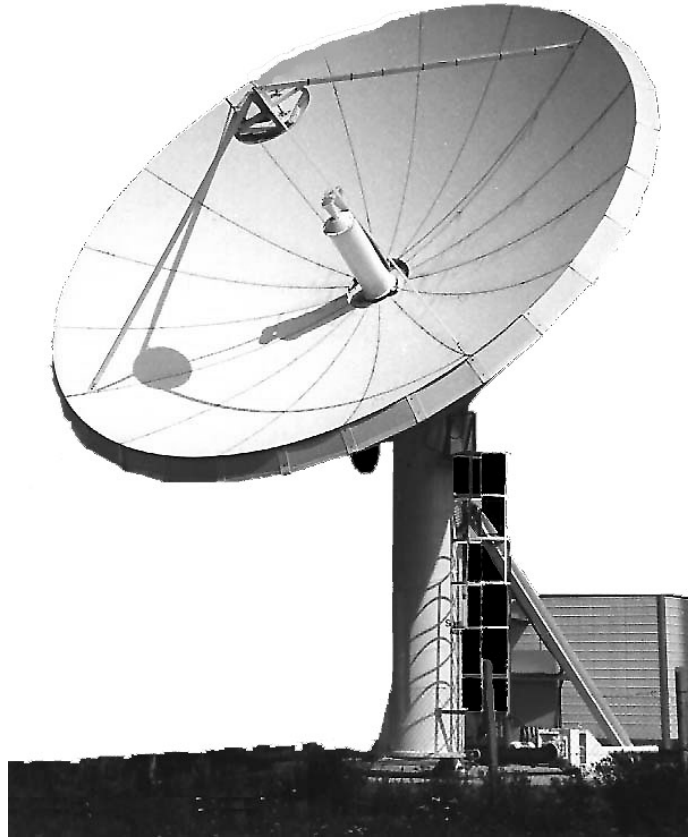

Figure 1-1. Typical Antenna System

The Model 8009A mount consists of a 168 inch [426 cm] tall structural tube that is supported at the top by two legs which extend to the rear of the antenna. The bottom of the tube is supported by a pivot bearing and is driven at the ground level location by the azimuth actuator. The elevation actuator is located atop the structural tube and behind the reflector hub. Both a single speed and a variable speed motorized actuator option is available. The total azimuth coverage is 160° in three overlapping 120° continuous sectors.

Azimuth sector changes can be accomplished in two hours by disassembling four bolts, repositioning the azimuth sector bars, and installing the four bolts in a different hole pattern in the bottom ring of the structural tube. The elevation axis will cover 0° to 90° in one continuous sector on antennas without reflector de-icing.

NOTE

With optional hot air de-icing installed, the minimum elevation angle is 5°.

The Model 8009A mount uses a 20-ton azimuth actuator and 15-ton elevation actuator. This actuator combination will drive the antenna in a 96 km/h [60 mi/h] wind at the extended actuator condition. The survivability envelope for the Model 8009A (120°) antenna mount is presented in Figure 1-2. Survival at 90° elevation (stow) is 201 km/h [125 mi/h].

CAUTION

The ability of the Model 8009A antenna to survive high winds depends upon the position of the antenna (elevation and azimuth pointing angles) when high winds occur. Use Figure 1-2 to identify the survivability envelope in which the antenna must be pointed to protect the azimuth actuator screw from excessive column loading when winds above 112 km/h (70 mi/h) are expected.

The Model 8009AE 120° and 180° are extreme environment mounts consisting of a 217 inch [551 cm] tall structural tube that is supported at the top by two legs which extend to the rear of the antenna. The bottom of the tube is supported by a pivot bearing and is driven at the ground level location by the azimuth actuator. The elevation actuator is located atop the structural tube and behind the reflector hub. A manual actuator, a motorized single speed actuator and a variable speed actuator is available. Total azimuth coverage for the Model 8009AE (120°) mount is 180° in three overlapping 120° continuous sectors. Selecting an alternate sector can be accomplished within (4) hours by reconfiguring the azimuth actuator location to a different set of anchor bolts on the foundation.

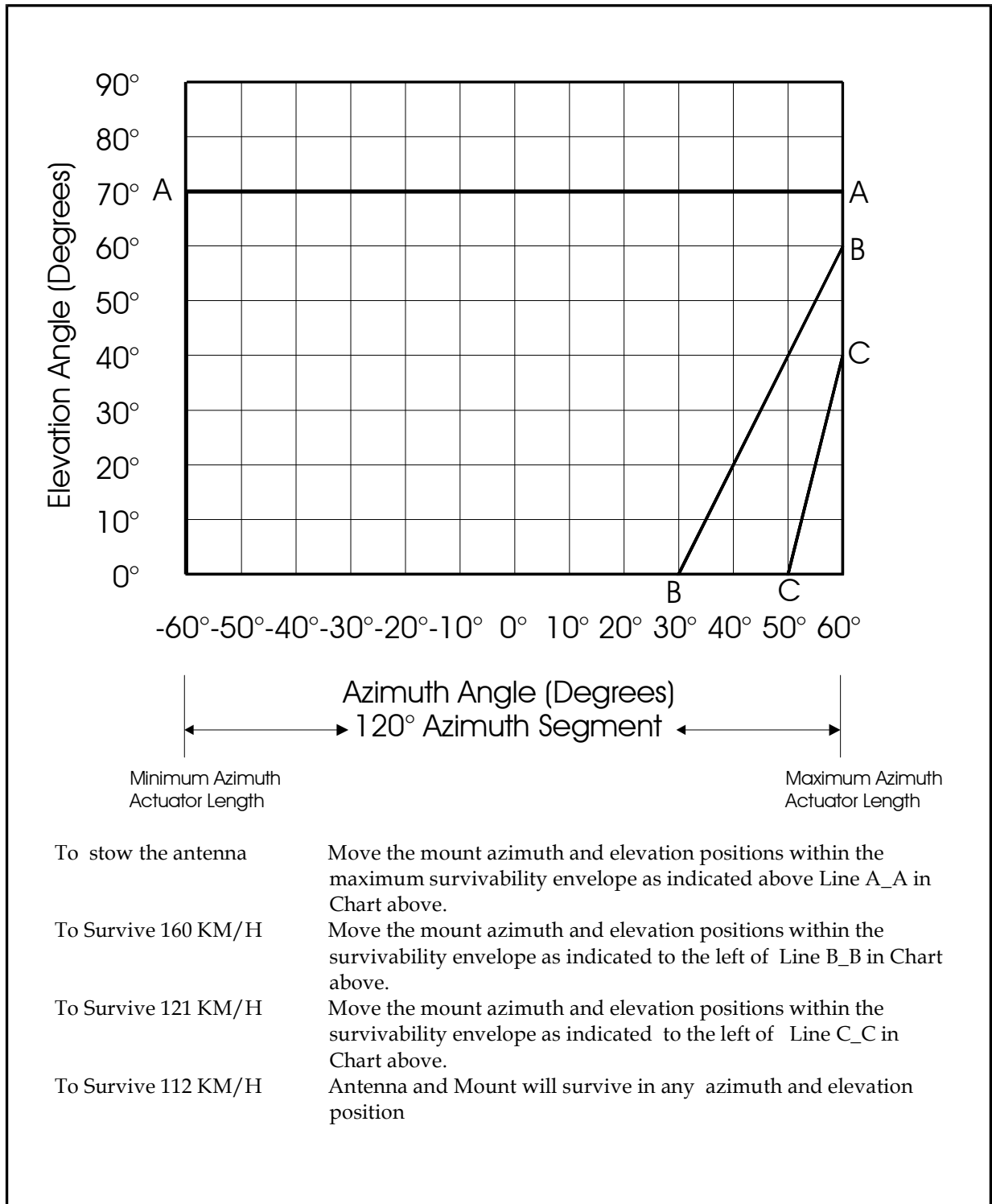

Figure 1-2. Elevation and Azimuth Angle Stow Chart for High Wind Conditions

Total azimuth coverage for the Model 8009AE (180°) mount is 180° continuous. The elevation axis for both the Model 8009AE 120° and 180° antenna will cover 0° to 90° in one continuous sector. Elevation travel will not be limited by reflector de-icing. The 30-ton azimuth actuator and 30-ton elevation actuator will allow the antenna to survive 201 km/h [125 mi/h] at any antenna orientation.

All manual drive actuators can be operated manually or with an auxiliary power source such as a drill motor. All motorized actuators may also be operated manually if required.

Grounding cables are provided to ensure system electrical grounding between the antenna reflector and the antenna mount structure. Tapped holes are provided in the mount base plates for attachment to a suitable foundation grounding system.

Included as optional equipment on the mount are a ladder and work platform assembly. These components provide safe and convenient access to the feed electronics inside the antenna hub and to the elevation drive motor for servicing and inspection. The ladder and platform are designed to be fully compatible with OSHA specifications.

Each antenna foundation is an essential part of the antenna installation. The foundation should be oriented so that the desired pointing angles can be achieved and accurately maintained under maximum wind loads.

NOTE

The Model 8009A (120°), Model 8009AE (120°) and Model 8009AE (180°) require different foundation specifications. See the appropriate foundation installation kit for the special features required for each antenna option.

It is imperative that competent engineering assistance be engaged to assure that the foundation is properly designed for the local site conditions and building codes. The contractor does not imply or warrant that the foundation design shown as typical on drawings in this manual, or other ViaSat documents, is appropriate for any particular locality or site condition. The structural steel mounts have been designed in accordance with the American Institute of Steel Construction (AISC) specifications for Design, Fabrication, and Erection of Structural Steel Buildings as presented in the Manual of Steel Construction, eighth edition (copyright 1980).

1.3 Reflector Description

The reflector, in combination with its shaped subreflector and feed system, is optically designed to yield high efficiency. The reflector consists of 48 precision stretch-formed aluminum panels. The panels are bolted together in the field to form a surface of revolution.

Each reflector assembly consists of a central hub assembly, to which are attached the radial trusses, intercostals, and the reflector panels. Ample space is provided inside the hub for mounting of redundant low-noise amplifiers (LNAs) and switching equipment. The hub has an access cover on the rear surface for convenient service and inspection of the feed electronics. Each reflector panel is aligned independently to ensure accuracy. The radial trusses support the panels and are locked together using the intercostals.

The hub assembly includes a machined plate for attaching the inner row of panels. All the panels are stretch-formed and have rigid back structures that are riveted into place.

The reflector panels are finished with a high reflectance white paint applied over a chromate conversion coating. (Other colors are available as options.) This special paint diffuses solar radiation to minimize subreflector heating from the reflector. The remainder of the equipment is primed and painted with two coats of gloss enamel.

Chapter 2

Installation

2.1 Introduction

This chapter provides instructions and guidelines for installing the 9-Meter antenna system. General safety precautions and procedures are also described.

2.1 Unpacking and Inspection

1. Inspect all shipping crates for visible damage.
2. Open the shipping crate and remove all packing material.
3. Inspect equipment for visible damage. While unpacking, carefully compare bill of lading or packing lists with equipment received. If equipment is missing, carefully check and sift through packing material to confirm. If errors are confirmed, notify ViaSat and carrier as soon as possible.

2.1.1 Damage or Loss During Shipment

When equipment is damaged or lost in transit, the delivering transportation company is required by law to make notation of damage or loss on the freight bill. The carrier, not the shipper, should be charged with all damage or loss. If damage or loss during shipping occurs, contact the carrier of the equipment. Save the shipping carton. The carrier's inspector must examine the carton and complete an inspection report.

2.1.2 What to do about Visible Loss or Damage

Make a note of any loss or evidence of external damage on the freight bill or receipt, and have it signed by the carrier's agent. Failure to adequately describe such external evidence of loss or damage may result in the carrier refusing to honor a damage claim. The form required to file such a claim will be supplied by the carrier.

2.1.3 What to do about Concealed Damage

Concealed damage means damage which does not become apparent until the unit has been unpacked. The contents may be damaged in transit due to rough handling, even though the crate may not show external damage. If you discover damage after unpacking the unit, make a written request for inspection by the carrier's agent within 15 days of the delivery date, then file a claim with the carrier since such damage is the carrier's responsibility. If

you follow these instructions carefully, ViaSat guarantees its full support of your claims to protect you against loss from concealed damage.

2.2 Equipment Return

ViaSat makes every reasonable effort to ensure that all items arrive safely and in working order. When equipment is received, which is not in working order, return the equipment to the factory for repair or replacement. Return the equipment according to the following procedure. This procedure will apply whenever equipment is returned for warranty or other services.

1. Notify ViaSat of the problem and request a Return Material Authorization (RMA) number and shipping instructions. For a current list of telephone and email contact information refer to Information section of the ViaSat internet site (<http://www.viasat.com>). Click on About Us, Contact Us and the link to Satellite Ground Systems.
2. Tag or identify defective equipment and note defect and circumstances, if any. If known, reference sales order, purchase order, and date equipment was received.
3. Reship equipment in original shipping container or use a strong shipping container to protect equipment during shipment.
4. Package equipment using shock-absorbing material around all sides of equipment.
5. Seal container securely and mark outside of container FRAGILE.

2.3 Safety

WARNING

Read and Understand all safety instructions before beginning any work. Death or severe injury may result if personnel fail to observe safety precautions.

2.3.1 Emergency Plan

Have an emergency plan. Know the procedures for obtaining first-aid and fire-fighting assistance. Plan your work and maintain good housekeeping; the safety and quality of the product are at stake.

2.3.2 General Mechanical Safety

These are general mechanical safety precautions that are not related to any specific procedure. They are recommended precautions that personnel must understand and apply.

- ⇒ Installation or maintenance of antennas may require persons to work at elevated work stations. Whenever persons are working at eight or more feet above ground and not on a guarded platform, they should wear safety belts with at least one, and preferably two, lanyards, with the exception that trained and qualified persons may work up to 25 feet (7.6 m) if on an approved ladder. In the sentence above, approved usually means that the ladder is tied off once the person has climbed but before work begins.
- ⇒ Assembly and installation of the reflector should only be done during fair weather and low wind conditions. Do not attempt to erect the antenna in winds exceeding 25 mi/h (40 km/h). Injury to personnel or damage to antenna may result if erection is attempted in high winds.
- ⇒ After the panels are installed on the reflector assembly, the reflector is very susceptible to moving during windy conditions. Ensure the reflector is properly tied down until the reflector is completely secured on the mount.
- ⇒ Overhead hazards, either because items may fall or because a person may strike them unintentionally, are typical around construction sites or during installation of large antennas. It is prudent to adopt the following rules:
 - ⇒ 1. Never stand underneath anything while it is being hoisted.

- ⇒ 2. Always wear a hard hat if someone is above you.

2.3.3 General Electrical Safety Summary

These are general electrical safety precautions that are not related to any specific procedure. These are recommended precautions that personnel must understand and apply.

- ⇒ Ensure that all electrical tools and equipment are properly grounded.
- ⇒ Avoid shorting circuits when using metal tools. Some circuits have high current capability which, when shorted, will flash and may cause burns and/or eye injury.
- ⇒ Remove all jewelry and exposed metal objects from body and clothing before performing maintenance, adjustments, and/or troubleshooting. Before working inside the equipment, remove all power, unless power is required to perform procedures. Do not replace parts with power on.
- ⇒ Replacement of fuses or other parts must be done using identical types and ratings. Substitution of non-identical parts may cause safety and fire hazards.
- ⇒ Servicing this equipment may require working with protective covers removed and ac power connected. Extreme caution must be exercised during these procedures.

2.3.4 Resuscitation

Personnel working with or near hazardous chemicals or voltages should be familiar with modern methods of resuscitation.

2.4 System Assembly

The assembly procedures presented in this section are based on the assumption that a powered lifting device of adequate size and capacity is used; therefore, the procedures given do not reflect consideration of limitations in lifting and handling equipment that might be encountered at any specific installation site. If a suitable crane is not available, it is possible to assemble the entire antenna without heavy hoisting equipment, provided sufficient manpower is available and a suitable elevated work platform can be provided so that the reflector may be assembled in place on top of the mount.

2.4.1 Site Preparation

A site should be selected and prepared in advance of the antenna installation. Refer to the 9-Meter Earth Station Antenna Site Preparation Technical Manual #42S314 for information needed to properly locate and install the foundation for this antenna system.

2.4.2 Recommended Tools and Equipment

Table 2-1 lists the tools and equipment required for efficient and convenient installation.

Table 2-1. Tools and Equipment Required For Installation	
Quantity	Description
1 Set	Socket, 3/8-inch drive, including 3-inch extension
1 Set	Socket, 3/4-inch drive, including 3-inch extension
1 Set	Combination wrenches up to 1 5/8-inch size
1 Each	Socket, 1 1/2-inch diameter, 4-inch long; used for turning anchor bolts.
1 Each	Socket, 1 15/16-inch size, 4-inch long; used for turning anchor bolt nuts
1 Each	Socket, 1 5/8-inch size, 2-inch long
1 Each	Socket, 1 1/2-inch size
1 Each	0.25 inch diameter file
1 Each	1.0 inch flat file
1 Each	Deburring tool
3 Each	3/16-inch drill bit
1 Each	3/8-inch drill motor
1 Each	3/4-inch drill motor
1 Each	100-foot power cord

Table 2-1. Tools and Equipment Required For Installation

Quantity	Description
4 Each	Straps, nylon, 30 feet long, minimum capacity 5000 pounds each, complete with lifting ring and attachment hooks
1 Each	Hoist, lever-operated cable or chain; 2-ton minimum capacity
2 Each	Drift pin, large size for aligning 1-inch holes
2 Each	Drift pin, large size for aligning 3/8- and 1/2-inch holes
1 Each	Ball peen hammer, 24-ounce
1 Each	10-foot stepladder
1 Each	25-foot extension stepladder
1 Each	Torque wrench, 600 ft-lb
1 Each	Torque wrench, 6 to 75 ft-lb
2 Each	Wrench, spud, 1 5/8-inch size
1 Each	Mallet, rawhide
1 Each	Rope, 50-foot, 3/8-inch manila or nylon; used for tie line
1 Each	Theodolite (wild T2)
1 Set	Short focus lens (GV 01 - GV 04)
1 Each	Right angle eyepiece
1 Each	Battery light kit
1 Each	Q-Beam spot light (for reflector adjustment)
1 Each	Level (spirit or bubble)
1 Each	Level, surface
1 Each	Pry-bar
6 Each	Clamp, 8-inch, C-type
1 Set	Small/medium/large Allen wrenches
1 Each	Screwdriver, #2 Phillips
1 Each	Plum Bob and string
1 Each	Screwdriver, medium, straight slot
1 Each	Band cutter
1 Each	Gauge, thickness ranges from 0.010 to 0.030 inch
1 Each	Angle finder or magnetic base inclinometer
1 Each	Grease gun with cartridges
1 Each	Crane, approximately 20-tons with a 80-foot boom

Table 2-1. Tools and Equipment Required For Installation

Quantity	Description
1 Each	Roll of masking tape or duct tape
1 Each	18.0-inch machine scale

2.4.3 Fastener Information

All threaded fasteners are galvanized, ASTM A325, high-strength, hexagonal-head screws (equivalent to SAE Grade 5) or stainless steel. The anchor bolts used in the foundation are made of SAE Grade 5 steel or better.

Each fastener must be correctly tightened at final assembly to ensure that it will carry its design load without working loose under vibration and will not allow slippage or separation of joined members. Thus, the structural integrity and pointing accuracy of the total antenna system depends upon the proper installation of quality fasteners.

This manual specifies the required torque value for installation of all major structural fasteners. Refer to Table 2-2 for the specific torque values for each fastener.

Table 2-2. Torque Values For Antenna Fasteners

Fastener Size (SAE)	Torque (ft-lb) tolerance $\pm 10\%$	
	Galvanized	Stainless
1/4-20	9 (12 Nm)	6 (8 Nm)
5/16-18	18 (24 Nm)	12 (16 Nm)
3/8-16	30 (40 Nm)	20 (26 Nm)
1/2-13	75 (100 Nm)	45 (60 Nm)
9/16-12	110 (149 Nm)	
5/8-11	150 (203 Nm)	
3/4-10	260 (353 Nm)	130 (176 Nm) (except as noted)
1 Anchor Bolts on Model 8009A mounts	240 to 275 ft - lb (325 to 372 Nm)	
1-1/4 Anchor Bolts on Model 8009AE mounts	360 to 440 ft - lb (488 to 596 Nm)	
1-8 Anchor Bolts	600 (813 Nm)	

NOTE

The required torque value for the foundation anchor bolts may not be accurately achieved by the turn-of-the-nut method. For these bolts, an accurate torque value of 400 to 450 lb-ft (542 to 610 Nm) is required.

2.4.4 Recommended Sequence of Assembly

In order to ensure proper and trouble-free installation, the following installation sequence is recommended. The sequence is designed to minimize crane usage time. The crane is only required for items 3, 5, and 6.

1. Site Preparation
2. Assembly of Reflector, Spars and Subreflector
3. Assembly of Mount and Actuators
4. Grouting Base Plate to Foundation
5. Reflector Installation
6. Feed and Waveguide Installation
7. Electrical Installation
8. Limit Switch Adjustment Procedure.

2.4.5 Preparation for Assembly

Before beginning the assembly read and understand the following instructions.

ViaSat guarantees the antenna specifications, provided that the reflector assembly procedure is performed by an installation crew trained and approved by ViaSat, Inc.

Carefully study the assembly drawings to understand how the complete reflector is assembled. The assembly drawings included in this manual are examples of typical reflector assemblies with motorized polarization drives without a de-ice system.

Clockwise and counterclockwise are as observed by a person looking down onto the front of the reflector while the hub is positioned with its rear side towards the ground.

Before starting the assembly, verify the following:

NOTE

Cleanliness of the precision mating parts that make up the reflector assembly is essential to proper fit and reflector surface accuracy. For this reason, only remove the reflector parts from their crates or pallets as required.

- Examine 48 reflector panels and 24 trusses in their crates.
 - Identify eight spar panels for the sub-reflector spar mounting tab attached to the spar trusses.
 - Identify four spar trusses by the spar support clevis welded to the tip end of the truss.
 - Examine the hub and note the orientation of the spar trusses (see Drawing 517577)

2.4.6 Assembly of Reflector, Spars and Subreflector

The following procedure describes the complete assembly of the reflector which includes the reflector hub, trusses, intercostals, spars, subreflector, and panels.

The basic reflector assembly sequence is:

- Install trusses and intercostals
- Install spars and subreflector
- Align trusses
- Install reflector panels to trusses
- Align Panels
- Tighten fasteners

Assemble the reflector on the ground by the following steps.

CAUTION

If it is necessary to walk inside the reflector during assembly, be sure to walk on the portion of the reflector closest to the hub. Avoid putting weight on unsupported parts of the reflector panels. Wear clean soft sole shoes or socks only. Extra care should be taken to protect the painted panel surface.

2.4.6.1 Installation of Trusses and Intercostals

Refer to drawing 517577C, 9-Meter Reflector Assembly, for the following procedure.

1. Remove hub assembly (item 31, drawing 517577) from packaging and place in upright position on stable wooden blocks or timbers. Raise the hub assembly at least 8 inches above the ground for working clearance. (Refer to drawing 517055 for hub assembly information.)

CAUTION

When assembling the reflector on the ground, the trusses should be installed by alternating from one side of the reflector to the other. This will prevent an unbalanced load that could cause the assembly to tip over.

2. Locate the jack mount ear on hub (item 3 drawing 517055 sheet 1, zone D-1).
3. Attach strut (item 17 drawing 517577 sheet 4, zone B-6) at first position clockwise from jack mount ear. Secure strut with one bolt (item 25), two washers (item 27), and one nut (item 26). Secure hardware finger tight.
4. Attach truss (item 23 drawing 517577 sheet 4, zone C-4) to hub using one bolt (25), two washers (27), and one nut (26) and to strut using four bolts (item 28), eight washers (item 30), and four nuts (item 29). Secure hardware finger tight.
5. Attach next clockwise strut and truss assemblies as described in steps 3 and 4.
6. Install top inner intercostal (item 18 drawing 517557 sheet 4, zone B-6) between two truss assemblies using two bolts (item 28), four washers (item 30), and two nuts (item 29). Secure hardware finger tight.
7. Install bottom inner middle intercostal (item 19 drawing 517557 sheet 4, zone B-6) between truss strut assemblies using two bolts (item 28), four washers (item 30), and two bolts (item 29). Secure hardware finger tight.
8. Install top outer intercostal (item 20 drawing 517577 sheet 4, zone B-6) between two truss assemblies using two bolts (item 28), four washers (item 30), and two nuts (item 29). Secure hardware finger tight.
9. Attach next clockwise strut and truss assemblies as described in steps 3 and 4. Then install intercostals as described in steps 6 through 8.

10. Attach strut (item 17 drawing 517577 sheet 4, zone B-6) at next clockwise position. Secure strut with one bolt (item 25), two washers (item 27), and one nut (item 26). Secure hardware finger tight.
11. Attach spar truss (item 22 drawing 517577 sheet 4, zone B-4) to hub using one bolt (25), two washers (27), and one nut (26) and to strut using four bolts (item 28), eight washers (item 30), and four nuts (item 29). Secure hardware finger tight.
12. Install top inner intercostal (item 18 drawing 517577 sheet 4, zone B-6) and left hand spar truss brace (item 21) to spar truss using bolt (item 33), two washers (item 30), and nut (item 29). Secure hardware finger tight.
13. Install top inner intercostal (item 18 drawing 517577 sheet 4, zone B-6) to other truss using bolt (item 28), two washers (item 30), and nut (item 29). Secure hardware finger tight.
14. Install bottom inner intercostal (item 19 drawing 517577 sheet 4, zone B-6) and left hand spar truss brace (item 21) to truss (without spar tab) using bolt (item 33), two washers (item 30), and nut (item 29). Secure hardware finger tight.
15. Install bottom inner intercostal (item 19 drawing 517577 sheet 4, zone B-6) to spar truss using bolt (item 28), two washers (item 30), and nut (item 29). Secure hardware finger tight.
16. Install top outer intercostal (item 20 drawing 517577 sheet 4, zone B-6) between two truss assemblies using two bolts (item 28), four washers (item 30), and two nuts (item 29). Secure hardware finger tight.
17. Attach next clockwise strut and truss assemblies as described in steps 3 and 4. Then install intercostals and right hand spar truss braces as described in steps 12 through 16. Secure hardware finger tight.
18. Attach next four clockwise strut and truss assemblies as described in steps 3 and 4. After each strut and truss assembly is installed, install intercostals as described in steps 6 through 8. Secure hardware finger tight. Secure hardware finger tight.
19. Attach next clockwise strut and spar truss assemblies as described in steps 10 and 11. Then install intercostals as described in steps 6 through 8. Secure hardware finger tight. Secure hardware finger tight.
20. Attach next five clockwise strut and truss assemblies as described in steps 3 and 4. After each strut and truss assembly is installed, install intercostals as described in steps 6 through 8. Secure hardware finger tight. Secure hardware finger tight.
21. Attach next clockwise strut and spar truss assemblies as described in steps 10 and 11. Then install intercostals as described in steps 6 through 8. Secure hardware finger tight.

22. Attach next five clockwise strut and truss assemblies as described in steps 3 and 4. After each strut and truss assembly is installed, install intercostals as described in steps 6 through 8. Secure hardware finger tight.
23. Attach next clockwise strut and spar truss assemblies as described in steps 10 and 11. Then install intercostals as described in steps 12 through 16. Secure hardware finger tight.
24. Attach the last two clockwise strut and truss assemblies as described in steps 3 and 4. After each strut and truss assembly is installed, install intercostals as described in steps 6 through 8. Secure hardware finger tight.

2.4.6.2 Installation of the Spars and Subreflector

Refer to drawing 517577C, 9-Meter Reflector Assembly, for the following procedure. Study sheet 3 to understand how the subreflector and spars fit together. Proceed with the assembly according to the following procedures:

1. Assemble four spars (item 16 drawing 517577 sheet 3, zone B-2) to top spar fitting (item 15) with 8 screws (item 8), 16 washers (item 9), and 8 nuts (item 10). Secure hardware finger tight.
2. Attach the subreflector support frame (item 6 drawing 517577 sheet 3, zone C-3) to the mounting frame (item 7) using three screws (item 8), six washers (item 9), and three nuts (item 10) in the three adjusting slots. Secure hardware finger tight.
3. Attach three threaded rods (item 12 drawing 517577 sheet 3, zone B-4) to the frames (items 6 and 7) using eight washers (item 9) and eight nuts (item 10) on each rod. Secure hardware finger tight.
4. Lift the frame assembly up to the spar assembly. Attach the mounting frame (item 7 drawing 517577 sheet 3, zone B-4) to the spars using four screws (item 8), eight washers (item 9), and four nuts (item 10). Secure hardware finger tight.
5. Set the subreflector (item 5 drawing 517577 sheet 3, zone B-4) concave side up on a padded surface for protection.
6. Install a nut (item 13) and a washer (item 11) onto each threaded stud (item 14) approximately 1.5 inches [3.8 cm] from the end, and screw the same end of each stud into one of the machined boss on the subreflector.
7. Install a nut (item 13) onto each threaded stud (item 14) approximately 3 inches [7.6 cm] from the free end, and place a washer (item 11) over the end of the stud and onto the nut.
8. Lift the subreflector up to the support frame and insert the studs into the corresponding holes in the frame. Secure the subreflector using three washers (item 11) and three nuts (item 13).
9. Choke a nylon strap around the spar assembly top fitting and attach it to the lifting hook of the crane.

10. Hoist the spar and subreflector assembly into the reflector and align the lower end of each spar with the attachment tab on a spar truss. Attach the spars to the truss tabs as shown in drawing 517577 sheet 2, using four screws (item 25), eight washers (item 27), and four nuts (item 26).
11. Torque all the fasteners used in the assembly and installation of the spars and subreflector to the values corresponding to the correct sizes as indicated on page 2-7.

2.4.6.3 Truss Alignment

Refer to drawing 517577C, 9-Meter Reflector Assembly, for the following procedure.

1. Install the theodolite mounting bracket onto the panel mounting ring in the hub using three 3/8 inch screws. It will only mount one way due to the dowel pins.
2. Install the theodolite onto the mounting bracket. Level the theodolite over its three feet using an 18-inch machine scale, measuring 16.850 inches [42.799 cm] up from the panel mounting ring. (See Figure 2-1.)
3. Zero the azimuth scale of the theodolite while looking at the center of the mounting bolt of the first truss to the hub.
4. Set the theodolite elevation angle to 80°-19'-38". Focus on the 1/4" diameter gage hole in the top of the end plate on the truss. Adjust the truss laterally and vertically so that the gage hole is centered on the theodolite telescope crosshairs. Tighten the mounting screws for the truss at the hub, and the screws which attach the outer diagonal braces to the truss.

NOTE

The truss tip elevation may be as much as 0°10' lower than the above setting, but should not be any higher.

5. Set the azimuth angle of the next truss at 15° clockwise from the previous truss. Set the elevation angle the same. Tighten the truss mounting screws and the intercostals between the two trusses. Also tighten the inner diagonal brace. Verify that the first truss remains as previously set.
6. Set the remaining trusses as in step 5. Only the first truss and its two adjacent trusses have diagonal braces attached to them.
7. Assure that all truss and intercostal fasteners are torqued as specified in Table 2-2 on page 2-7.

2.4.6.4 Installation of Reflector Panels

Refer to drawing 517577, 9-Meter Reflector Assembly, for the following procedure.

1. Install four threaded rods (item 35) one in each hole on the inner truss pad using two washers (item 9) and two nuts (item 10) on each rod. Install another nut (item 10) 2 1/8-inches (5.4 cm) above pad on each rod. Place one washer (item 9) on top of each nut. (These threaded rods will be used to mount the panels.)
2. Install two threaded rods (item 35) one in each hole on outer truss pad using two washers (item 9) and two nuts (item 10) on each rod. Install another nut (item 10) 1 1/2-inches (3.8 cm) above pad on each rod. Place one washer (item 9) on top of each nut.
3. Extend 4-foot lengths of 2 x 4 lumber from halfway out on trusses to the ground. Clamp boards securely in place with "C" type clamps. This should be done on every other truss to provide outrigger stability to the reflector while it is being assembled.

CAUTION

As the reflector panels are assembled, the reflector will become highly susceptible to wind forces; therefore, secure the hub-truss assembly as indicated in the following step before installing panels.

4. Tie six equally spaced trusses to ground stakes using wire rope. Secure rope to outermost junction on the lower main radial rib of the truss. Do not use a mechanical device to tighten the ropes since this could damage the trusses. This should prevent the reflector from overturning. This tie-down procedure is a mandatory precaution if the reflector is to be left on the ground overnight and unattended.

NOTE

There are two tiers of 24 panels each for the 9-meter antenna. The inner tier of panels is installed first, then the outer tier.

5. Place inner panel (item 4) on threaded rods at position closest to hub as shown in drawing.
6. Secure outer portion of panel to rods using two flat washers (item 9) and two nuts (item 10).
7. Secure inner portion of panel to hub using washer (item 9) and screw (item 32).

8. Roughly align panel by moving threaded rod up or down with nuts on truss. Sight the outer corners of each panel using the theodolite and data provided in Table 2-3. (This will minimize the final adjustments.) Set the outer edge elevation angle to $87^{\circ} - 26' - 20''$. Set the azimuth of the lateral edge of the panels to $0^{\circ} - 02'$ each side of the 15° increments. Fully tighten the adjusting nuts.

Table 2-3. Panel Rough Alignment		
Panel Rough Alignment - 2 Tiers, 24 Panels each at 15° Sight side and outer edges of panel at corner		
	Inner Panel	Outer Panel
Outer Edge Elevation	87-26-20	78-15-12
Side Edge 15° Increment \pm	0-02-00	0-01-11

9. Repeat steps 5 through 8 for the remainder of the panels on the inner row, spacing panels $1/8$ inch (0.32 cm) apart.
10. Starting at a spar tab position, place left spar panel (item 1) on threaded rods spaced $1/8$ inch (0.32 cm) out from inner panel. See drawing sheet 1.
11. Secure panel to rods using four washers (item 9) and four nuts (item 10).
12. Align panel surface flush to adjacent inner panel by moving threaded rod up or down with nuts on truss. Align outer corners using theodolite. Refer to Table 2-3.
13. Place right spar panel (item 2) on threaded rods at next clockwise position.
14. Secure panel to rods using four washers (item 9) and four nuts (item 10).
15. Align panel flush to adjacent panels by moving threaded rod up or down with nuts on truss. Align outer corners using theodolite.
16. Place outer panel (item 3) on threaded rods at next counterclockwise position.
17. Secure panel to rods using four washers (item 9) and four nuts (item 10).
18. Align panel flush to adjacent panels by moving threaded rod up or down with nuts on truss. Align outer corners using theodolite.
19. Repeat steps 16 through 18 for the next four panels on the outer row.
20. Repeat steps 10 through 19 three times to complete outer row of panels.

2.4.6.5 Reflector Alignment

Refer to Figure 2-1 for clarification of alignment procedures. The theodolite

mounting bracket, template arm, drill template, and setting data for alignment are located in Alignment Kit #516212.

1. Verify that the theodolite is still level with respect to the panel mounting ring, at a height of 16.850 inches [42.799 cm].
2. Pin the template arm to the tab on the slip ring below the theodolite mounting plate.

NOTE

The splice plates and bushing plates must face away from the surface of the reflector. Any kinks in the template should be smoothed in order for the curve of the template to follow the curve of the reflector.

3. Attach section 1 of the drill template to template arm using two #8-32 screws. Attach section 2 of drill template to section 1 using two #8-32 screws. Section 3 of the template will not be used for the 9-meter reflector alignment.
4. At 3 inches to the left and right of each radial panel joint, drill #13 or 3/16" holes in the panel surface using the 3rd, 4th, and 7th drill bushings in the template. Assure that no burrs protrude into the holes or above the panel surface.
5. Install a theodolite target into each of the drilled holes in the reflector, fully seated. The target should be rotated in the hole so that the flat surface containing the white diamond shapes is facing toward the theodolite.
6. Set the theodolite elevation angle at the appropriate value for the target row being adjusted. The angles are given on a data sheet packed along with the drill template in the alignment kit. If the data is missing from the kit, the values in Table 2-4 may be used to obtain a reasonably accurate setting.

**Table 2-4. Final Alignment Target Measurements
- Sight Center of the Middle Diamond**

Target Row	Target Location	Target Angle
1	Panel 1 Outside	87-50-20
2	Panel 2 Inside	86-47-48
3	Panel 2 Outside	78-29-24

7. The Target Detail in Figure 2-1 shows the layout of the target. An ideal setting will occur when the theodolite elevation crosshair is centered on the middle diamond. Dimensions to other diamond points are given as an indication of the adjustment required to obtain the ideal setting.
8. Beginning at the inner row of targets and working outward in concentric circles, adjust the panel corner adjustment below each target. After each adjustment, fully tighten the adjusting nuts and recheck the setting.

CAUTION

Do not lean on or apply any weight to the theodolite mounting bracket while setting a target. This will cause an error in the adjustment.

9. After final alignment, there should be no settings where the theodolite elevation crosshair is more than halfway from the center to the tip of the middle diamond. This represents 0.010 inches error.
10. Read and record the final readings of target elevations on the form in Table 2-5. Count the number of 0, 5 and 10 thousandths readings, and write these down in the Summary under 'Count'. Follow the remainder of the calculation portion of the table to determine the overall setting accuracy of the reflector.

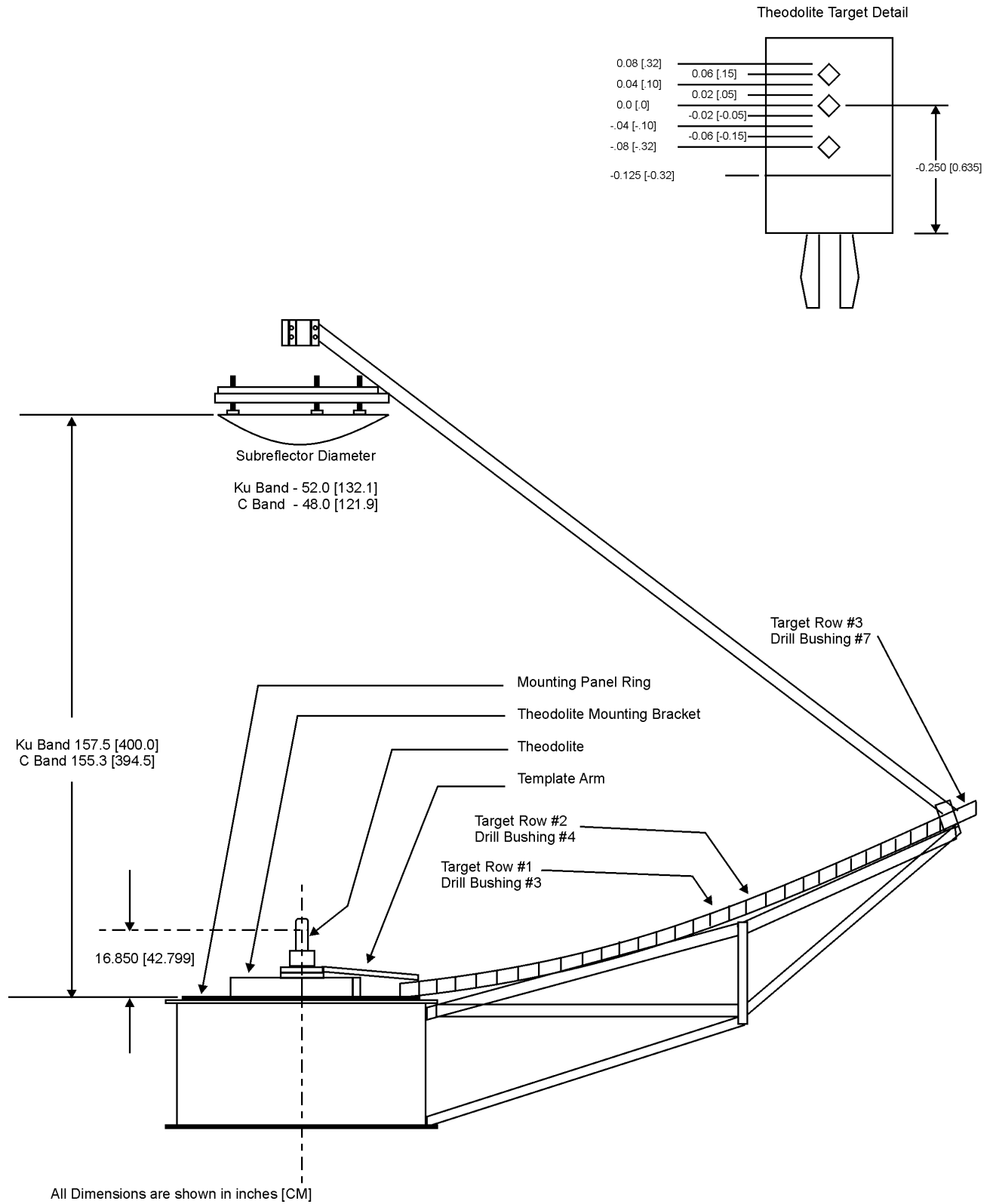

Figure 2-1. 9-Meter Antenna Reflector and Subreflector Alignment

Table 2-5. 9-Meter Reflector Alignment Record			
Target #	Row 1	Row 2	Row 3
1			
2			
3			
4			
5			
6			
7			
8			
9			
10			
11			
12			
13			
14			
15			
16			
17			
18			
19			
20			
21			
22			
23			
24			
25			
26			
27			
28			
29			
30			
31			
32			
33			
34			
35			
36			
37			
38			
39			
40			
41			
42			
43			
44			
45			
46			
47			
48			

Summary		
Readings	Count	Product
.000	_____	= _____ 0
.005	_____	= _____
.010	_____	= _____
Product Total		= _____
Divide by 144		= _____
Square Root		= _____
RMS		= <input style="width: 100px; height: 20px;" type="text"/>

Customer
Site Location
Antenna Serial #
Performed By
Date

2.4.6.6 Subreflector Alignment

1. Apply a small amount of light grease or oil to the target mirror shaft. Screw the target mirror into the hole in the apex of the subreflector a few turns. It does not need to be tightened.
2. Rotate the mirror so that the Crosshairs are aligned with the adjustment directions of the subreflector mounting frame.
3. Use the right angle lens set of the theodolite to set the theodolite elevation angle to 0° (vertical) and view the mirror crosshairs. Rotate the theodolite azimuth to orient the theodolite crosshairs even with the mirror crosshairs.
4. Using the three threaded subreflector adjusting rods, adjust the distance of the subreflector from the panel mounting ring to match the dimension given in Figure 2-1 for the appropriate antenna operational frequency band. Make the measurement the same at the edge of the subreflector near each of the three rods.
5. Focus the theodolite toward infinity until the theodolite telescope barrel becomes visible in the mirror. Adjust the subreflector tilt using the three threaded subreflector adjusting rods. The theodolite crosshairs should appear centered in the end of the theodolite telescope barrel.
6. Reduce the focal distance of the theodolite until the mirror crosshairs are clearly visible. Adjust the lateral location of the subreflector until the mirror crosshairs and the theodolite crosshairs coincide.
7. Tighten all the subreflector adjusting fasteners. Verify that all adjustments have been maintained.
8. Remove the mirror from the subreflector.
9. Apply duct tape to the lower nuts on the three threaded subreflector adjusting rods to maintain the tilt and focal length setting; then remove the upper nuts from the threaded rods. Lower and remove the subreflector from the mounting frame and set it aside until the reflector has been lifted onto the mount.

2.4.7 Mount Installation

The antenna foundation must be structurally adequate and provide suitable anchor bolts located and installed per foundation plan. Refer to Site Preparation manual, #42S314, for site preparation and foundation details for the appropriate mount [Model 8009A (120°), Model 8009AE (120°) or Model 8009AE (180°)].

WARNING

All personnel atop the mount must use safety belts and have all ladders properly and safely secured.

2.4.7.1 Model 8009A Mount/Actuator Installation Procedure**NOTE**

Procedures in this section are specifically for the Model 8009A. If installing a Model 8009AE 120° see instructions given in section 2.4.7.2 beginning on page 2-24. If installing a Model 8009AE 180° 9-Meter Antenna System see instructions given in section 2.4.7.3 beginning on page 2-27.

Drawing 519054 provides the installation drawing for the 9-Meter 120° mount/actuators. Refer to this drawing for clarification of the follow procedure. The following steps are recommended for installing the antenna mount and actuators on the foundation.

1. Ensure the antenna foundation is structurally adequate and provides suitable anchor bolts located per foundation plan 519920 before installing the antenna mount.
2. Locate (Qty 18) 1.0 inch galvanize washers (item 24) and (Qty 18) 1-8 UNC galvanized nuts (item 25). Install one nut on each anchor bolt at approximately 0.5 inch above the foundation surface. The 0.5 inch clearance will be required for leveling the mount. Place one washer on top of each nut as shown in Figure 2-2.

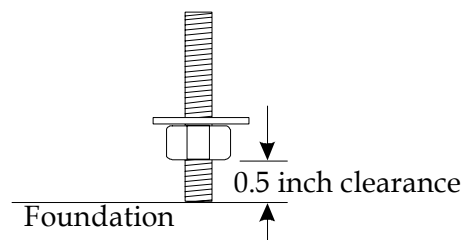

Figure 2-2 Installing Leveling Nuts

3. Secure a nylon strap to the azimuth actuator assembly (item 5). Lift the assembly with a crane and position over foundation anchor bolts. Locate (Qty 4) 1.0 inch galvanized washers (item 24) and (Qty 4) 1-8 UNC fluorocarbon nuts (item 26). Loosely install nuts and washers on anchor bolts and remove the nylon strap.
4. Secure a nylon strap to each leg (item 4) at approximately 87.0 inches from the 1.0 inch base plate as shown on sheet 5 of Drawing 519054. Lift each leg with a crane and position over foundation anchor bolts. Locate (Qty 8) 1.0 inch galvanized washers (item 24) and (Qty 8) 1-8 UNC fluorocarbon nuts (item 26). Loosely install nuts and washers on anchor bolts and remove the nylon strap.

NOTE

Complete steps 5 and 6 while the mount (item 1) is laying horizontal on the ground.

5. Refer to sheets 3 and 4 of drawing 519054. Attach (Qty 2) electrical grounding cables (item 17) to ground cable brackets (items 15 and 16) with .5-13 UNC screws, washers, and nuts (items 36, 37 and 38). Tighten 0.5 inch hardware to 75 ft-lb (100 Nm).
6. Secure a nylon strap to the elevation actuator assembly (item 10). Remove the 1.5 inch retainer rings, 1.5 inch diameter clevis pin, and 1.38 inch washers from assembly. Lift the assembly with a crane and position the jack clevis over attachment point on mount (item 1) as shown on sheet 3 of Drawing 519054. Reassemble pivot pin through the clevis, bearing, bearing spacers, washers and install retainer rings.
7. Refer to 9-Meter Ladder and Platform Installation drawing 523079 , attach the ladder and platform per the following procedure. If the optional ladder is not to be installed proceed to step 13.
8. Locate the ladder mount (item 1), ladder (item 2) ladder brace (item 3) and ladder hanger (item 4). Loosely attach items to mount with 0.5-inch hardware (items 10, 11, 12, 13, 14, and 15) as shown in drawing.
9. Locate the platform step (item 7) and loosely attach to the mount and ladder (item 2) with 0.5-inch hardware.
10. Position the platform (item 5) to the mount and ladder and attach with 0.5-inch hardware as shown in drawing.
11. Attach platform brace (item 6) and rail brace (item 8) to mount with 0.5-inch hardware.
12. Tighten all 0.5-inch hardware on ladder and platform to 75 ft-lb (100 Nm).
13. Refer to sheet 3 and note 5 on sheet 2 of drawing 519054. Secure a steel cable to the mount attachment lifting point identified by note 5. Lift the mount assembly (3500 lb or 1588 kg) with the crane approximately 39.0 inches (1 meter) and remove the upper shipping brace. Extra care shall be taken when attaching the steel lifting cable to prevent damage to the ladder and platform (if installed).
14. Secure the elevation actuator assembly, during lifting, with a nylon strap or rope attached to the elevation actuator protection tube and 1.0 inch clearance holes used for mounting shipping brace.
15. Place several wood blocks under the lower end of mount while lifting the mount to a vertical position.
16. Refer to sheet 4 of drawing 519054. Remove the lower shipping brace .

17. Place the lower azimuth pivot (item 3) over the foundation anchor bolts and loosely install (Qty 6) 1.0 inch galvanized washers (item 24) and (Qty 6) 1-8 UNC fluorocarbon nuts (item 26).
18. Place a surface level on the top surface of the lower azimuth pivot pin and adjust (3) equally spaced 1-8 UNC anchor nuts on the bottom side of the base plate until the pivot is level. The other (3) bottom nuts should be lowered slightly to avoid binding the base plate. Hold the bottom (3) nuts which are in contact with the base plate fixed with a wrench and tighten (3) top nuts against the base plate to 240 ft-lb (325 Nm).
19. Check the level to ensure the lower azimuth pivot pin is level.
20. Rotate the remaining (3) bottom nuts and (3) top nuts against the base plate. Caution must be taken not to distort the leveled pin. Tighten all anchor nuts to 240 to 275 ft-lb (325 to 372 Nm).
21. Install eye bolt (item 22) to upper azimuth pivot (item 2) as shown on sheet 3 of Drawing 519054. Attach a string to the eye bolt and suspend a plum bob directly over the lower azimuth pivot as shown on sheet 5.
22. Attach upper azimuth pivot (item 2) to legs (item 4) with 1.0-inch hardware (items 24, 25 and 27). Adjust the leg anchor bolts as require to install hardware and secure a ground cable bracket (item 16) under one of the 1-8 UNC bolts. Tighten 1.0 inch hardware to 600 ft-lb (813 Nm).
23. Remove the crane from the mount.
24. Adjust the anchor bolt nuts securing the legs to the foundation as required until the upper and lower pivot is plum (vertically aligned). See sheet 5 of drawing 519054.
25. Attach wrench to the top and bottom 1-8 UNC foundation anchor nuts and tighten to 240 to 275 ft-lb (325 to 372 Nm). Be sure to evenly tighten the nuts so as not to distort the legs.
26. Loosen hose clamps as required and slide back the azimuth actuator boot.
27. Extend the azimuth actuator screw by rotating the screw by the clevis until the pin to pin jack length is greater than 64.0 inches (162.5 cm).
28. Remove the retainer rings and PVC spacers from the azimuth actuator clevis pin.
29. Attach azimuth arm spacer and sector bars (items 6,7,8 and 9) to the pivot pin and lower mount flange with 1-8 UNC galvanized hardware as shown in sheets 6 and 7 of Drawing 519054.
30. Replace retainer rings to clevis pivot pin.

31. Install (Qty 1) grease fitting (item 32) in clevis pivot pin as shown in sheet 7, view B-B of Drawing 519054. Add grease to grease fitting and pivot pin.
32. With a level placed directly on the jack screw adjust anchor bolts until the actuator screw is level with the mount. Tighten 1.0 inch hardware. Torque anchor pin nuts to a minimum of 240 ft-lb (325 Nm) to maximum of 275 ft-lb (372 Nm).
33. Replace boot and hose clamps.

2.4.7.2 Model 8009AE 120° Mount/Actuator Installation Procedure

NOTE

Procedures in this section are specifically for the Model 8009AE 120° Antenna Mount for Extreme Environment 9-Meter Antenna System. If installing a Model 8009A 9-Meter Antenna System see instructions given in section 2.4.7.1 beginning on page 2-21. If installing a Model 8009AE 180° 9-Meter Antenna System see instructions given in section 2.4.7.3 beginning on page 2-27.

Drawing 517098 provides the installation drawing for the 9/11-Meter Antenna 120° mount/actuators. Refer to this drawing for clarification of the follow procedure. The following steps are recommended for installing the antenna mount and actuators on the foundation.

1. Ensure the antenna foundation is structurally adequate and provides suitable anchor bolts as specified in the Site Preparation Manual 42S314 before installing the antenna mount.
2. Refer to sheet 2 of drawing 517098. Locate (Qty 20) 1.25 inch galvanize washers (item 218) and (Qty 18) 1.25-7 UNC galvanized nuts (item 219). Install one nut on each anchor bolt at approximately 0.5 inch above the foundation surface. The 0.5 inch clearance will be required for leveling the mount. Place one washer on top of each nut in Figure 2-2 on page 2-21.
3. Refer to sheet 5 of drawing 517098. Secure a nylon strap to the azimuth actuator assembly (item 17). Lift the assembly with a crane and position over foundation anchor bolts. Locate (Qty 6) 1.25 inch galvanized washers (item 218) and (Qty 6) 1.25-7 UNC nuts (item 219). Loosely install nuts and washers on anchor bolts and remove the nylon strap.
4. Refer to sheet 2 of drawing 517098. Locate (Qty 8) 1.25 inch galvanized washers (item 218) and (Qty 8) 1.25-7 UNC (item 219). Secure a nylon strap to each leg (item 2) at approximately the center. Lift each leg with a crane and position over foundation anchor bolts. Loosely install four nuts and

washers to secure each leg on anchor bolts. Disconnect crane and remove the nylon straps.

5. Secure a nylon strap to the elevation actuator assembly (item 18). Remove the cotter pins (item 16), clevis pin (item 21), spacers (item 22) and washers (item 205) from assembly.
6. Lift the assembly with a crane and position the jack clevis over attachment point on mount (item 1) as shown on sheet 6 of Drawing 517098. Reassemble pivot pin (item 21) through the clevis, with spacers (item 22) and washers (item 205) and cotter pins (item 16).
7. Attach the ladder and platform per the following procedure. If the optional ladder is not to be installed proceed to step 9.
8. Locate the ladder and platform parts and loosely attach to mount (item 1) as shown on sheets 3 and 4 of drawing 517098. When ladder and platform are attached tighten all 3/8-inch hardware on ladder and platform to 20 ft-lb (26 Nm).
9. Secure the elevation actuator assembly with a nylon strap or rope attached to the elevation actuator protection tube and 1.0 inch clearance holes used for mounting shipping brace.

Secure a steel cable to the mount lifting points (identified by

10. Figure 2-3) using two shackles.

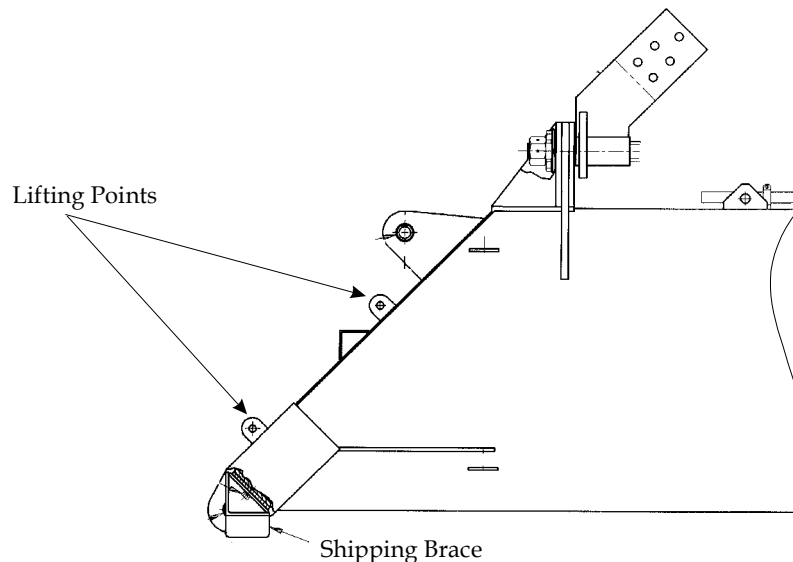

Figure 2-3 Rigging Lifting Points

11. Lift the mount assembly (3500 lb or 1588 kg) with the crane approximately 39.0 inches (1 meter) and remove the upper shipping brace. Extra care shall be taken when attaching the steel lifting cable to prevent damage to the ladder and platform (if installed).
12. Place several wood blocks under the lower end of mount while lifting the mount to a vertical position.
13. Remove the lower shipping brace.
14. Place the lower azimuth pivot (item 3 on drawing 477697) over the foundation anchor bolts and loosely install (Qty 6) 1.25 inch galvanized washers (item 218) and (Qty 6) 1.25-7 UNC nuts (item 219).
15. Install (Qty 3) 3/4-10 X 3.0 screws into lower azimuth pivot base.
16. Place a surface level on the top surface of the lower azimuth pivot pin and adjust (3) equally spaced 3/4-10 X 3.0 screws on the base plate until the pivot is level. Tighten three of the six top nuts against the base plate to 240 ft-lb (325 Nm).
17. Check the level to ensure the lower azimuth pivot pin is level.
18. Rotate the remaining (3) bottom nuts and (3) top nuts against the base plate. Caution must be taken not to distort the leveled pin. Tighten all anchor nuts to 240 to 275 ft-lb (325 to 372 Nm).
19. Install 1/4-20 X 1.0 eye bolt to upper azimuth pivot (item 2 drawing 477697). Attach a string to the eye bolt and suspend a plum bob directly over the lower azimuth pivot (item 3 drawing 477697).
20. Attach upper azimuth pivot (item 2) to legs (item 4) with 1.0-inch hardware (items 201, 202 and 203).
21. Adjust the leg anchor bolts as required to install hardware. Tighten 1.0 inch hardware to 600 ft-lb (813 Nm).
22. Remove the crane from the mount.
23. Adjust the anchor bolt nuts and leveling screws to the foundation as required until the upper and lower pivot is plum (vertically aligned).
24. Attach wrench to the top and bottom 1-8 UNC foundation anchor nuts and tighten to 240 to 275 ft-lb (325 to 372 Nm). Be sure to evenly tighten the nuts so as not to distort the legs.
25. Loosen hose clamps as required and slide back the azimuth actuator boot.
26. Extend the azimuth actuator screw by rotating the screw by the clevis until the pin to pin jack length is greater than 64.0 inches (162.5 cm).

27. Remove the pin (item 214) and retainer ring (item 215) from the azimuth actuator clevis pin.
28. Attach azimuth mount (item 1) to the actuator (item 17). Install pivot pin and retaining ring (item 215).
29. Install grease fitting (item 216) in clevis pivot pin. Add grease to grease fitting and pivot pin.
30. With a level placed directly on the jack screw adjust anchor bolts until the actuator screw is level with the mount. Tighten 1.25 inch hardware. Torque anchor pin nuts to a minimum of 360 ft-lb (488 Nm) to maximum of 440 ft-lb (596 Nm).
31. Replace boot and hose clamps.

2.4.7.3 Model 8009AE 180° Mount/Actuator Installation Procedure

NOTE

Procedures in this section are specifically for the Model 8009AE 180° Antenna Mount for Extreme Environment 9-Meter Antenna System. If installing a Model 8009A 9-Meter Antenna System see instructions given in section 2.4.7.1 beginning on page 2-21. If installing a Model 8009AE 120° 9-Meter Antenna System see instructions given in section 2.4.7.2 beginning on page 2-24.

Drawing 517097 provides the installation drawing for the 9-Meter Antenna 180° mount/actuators. Refer to this drawing for clarification of the follow procedure. The following steps are recommended for installing the antenna mount and actuators on the foundation.

1. Ensure the antenna foundation is structurally adequate and provides suitable anchor bolts as specified in the Site Preparation Manual 42S314 before installing the antenna mount.
2. Refer to sheet 2 of drawing 517097. Locate (Qty 20) 1.25 inch galvanize washers (item 218) and (Qty 18) 1.25-7 UNC galvanized nuts (item 219). Install one nut on each anchor bolt at approximately 0.5 inch above the foundation surface. The 0.5 inch clearance will be required for leveling the mount. Place one washer on top of each nut as shown in Figure 2-2 on page 2-21.
3. Refer to sheet 5 of drawing 517097. Secure a nylon strap to the azimuth actuator assembly (item 17). Lift the assembly with a crane and position over foundation anchor bolts. Locate (Qty 6) 1.25 inch galvanized washers (item 218) and (Qty 6) 1.25-7 UNC nuts (item 219). Loosely install nuts and washers on anchor bolts and remove the nylon strap.

4. Refer to sheet 2 of drawing 517097. Locate (Qty 8) 1.25 inch galvanized washers (item 218) and (Qty 8) 1.25-7 UNC (item 219). Secure a nylon strap to each leg (item 2) at approximately the center. Lift each leg with a crane and position over foundation anchor bolts. Loosely install four nuts and washers to secure each leg on anchor bolts. Disconnect crane and remove the nylon straps.
5. Secure a nylon strap to the elevation actuator assembly (item 18). Remove the cotter pins (item 16), clevis pin (item 21), spacers (item 22) and washers (item 205) from assembly.
6. Lift the assembly with a crane and position the jack clevis over attachment point on mount (item 1) as shown on sheet 6 of Drawing 517097. Reassemble pivot pin (item 21) through the clevis, with spacers (item 22) and washers (item 205) and cotter pins (item 16).
7. Attach the ladder and platform per the following procedure. If the optional ladder is not to be installed proceed to step 9.
8. Locate the ladder and platform parts and loosely attach to mount (item 1) as shown on sheets 3 and 4 of drawing 517097. When ladder and platform are attached tighten all 3/8-inch hardware on ladder and platform to 20 ft-lb (26 Nm).
9. Secure the elevation actuator assembly with a nylon strap or rope attached to the elevation actuator protection tube and 1.0 inch clearance holes used for mounting shipping brace.
10. Secure a steel cable to the mount lifting points (identified by Figure 2-4) using two shackles.

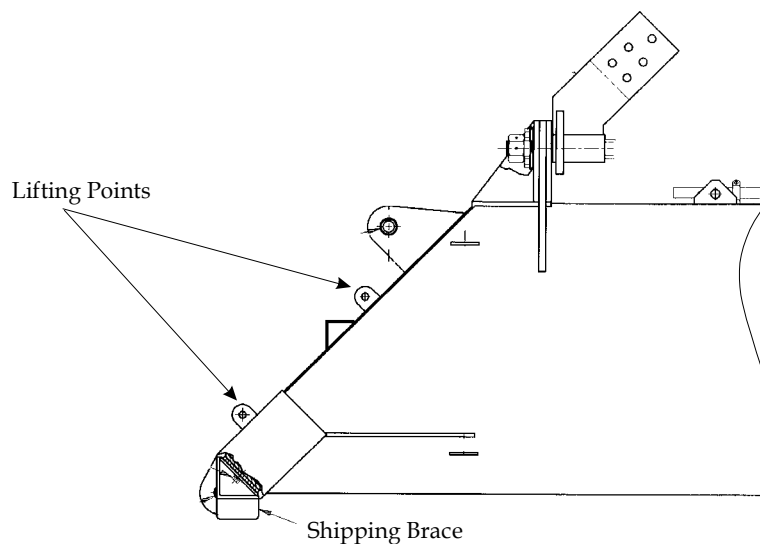

Figure 2-4 Rigging Lifting Points

11. Lift the mount assembly (3500 lb or 1588 kg) with the crane approximately 39.0 inches (1 meter) and remove the upper shipping brace. Extra care shall be taken when attaching the steel lifting cable to prevent damage to the ladder and platform (if installed).
12. Place several wood blocks under the lower end of mount while lifting the mount to a vertical position.
13. Remove the lower shipping brace.
14. Place the lower azimuth pivot (item 3 on drawing 477697) over the foundation anchor bolts and loosely install (Qty 6) 1.25 inch galvanized washers (item 214) and (Qty 6) 1.25-7 UNC nuts (item 215).
15. Install (Qty 3) 3/4-10 X 3.0 screws into lower azimuth pivot base.
16. Place a surface level on the top surface of the lower azimuth pivot pin and adjust (3) equally spaced 3/4-10 X 3.0 screws on the base plate until the pivot is level. Tighten three of the six top nuts against the base plate to 240 ft-lb (325 Nm).
17. Check the level to ensure the lower azimuth pivot pin is level.
18. Rotate the remaining (3) bottom nuts and (3) top nuts against the base plate. Caution must be taken not to distort the leveled pin. Tighten all anchor nuts to 240 to 275 ft-lb (325 to 372 Nm).
19. Install 1/4-20 X 1.0 eye bolt to upper azimuth pivot (item 2 drawing 477697). Attach a string to the eye bolt and suspend a plum bob directly over the lower azimuth pivot (item 3 drawing 477697).
20. Attach upper azimuth pivot (item 2) to legs (item 4) with 1.0-inch hardware (items 201, 202 and 203).
21. Adjust the leg anchor bolts as required to install hardware. Tighten 1.0 inch hardware to 600 ft-lb (813 Nm).
22. Remove the crane from the mount.
23. Adjust the anchor bolt nuts and leveling screws to the foundation as required until the upper and lower pivot is plum (vertically aligned).
24. Attach wrench to the top and bottom 1-8 UNC foundation anchor nuts and tighten to 240 to 275 ft-lb (325 to 372 Nm). Be sure to evenly tighten the nuts so as not to distort the legs.
25. Attach azimuth mount (item 1) to the actuator (item 17) using ten 1.0-8 X 3 galvanized bolts (item 218) and 1.0 galvanized flat washers (item 219).
26. Install centering arm (item 23) as shown on sheet 5 of drawing.

27. With a level placed directly on the jack screw adjust anchor bolts until the actuator screw is level with the mount. Tighten 1.25 inch hardware. Torque anchor pin nuts to a minimum of 360 ft-lb (488 Nm) to maximum of 440 ft-lb (596 Nm).

2.4.8 Grouting Baseplate to Foundation, Models 8009A and 8009AE

Grout is used between the concrete foundation surface and the four base plates to ensure a rigid, load-bearing connection between the mount and the foundation. It is important that the grout manufacturer's instructions be followed. These instructions are packaged with the grout.

For convenience, the essentials of the procedure are repeated as follows:

The grout must be 1.0-inch thick minimum at all locations (see Figure 2-23). Verify that each anchor bolt nut will have no less than two threads above the nut. The normal ambient temperature range for good "early-strength" grouting is 55°F to 80°F (13°C to 27°C). When temperatures at the job site are outside this range, the procedures given here must be modified to compensate for the high or low temperature. If the temperature is outside the range, perform one of the following procedures before proceeding to the grouting procedure.

2.4.8.1 Hot Weather Grouting

Temperatures above 80°F (27°C) accelerate hardening of the grout, reducing the time that the grout remains workable after mixing; therefore, it is necessary that either procedures be used which permit placing of the grout more quickly, or the available working time increased by cooling the mixture and the mount base plates.

If the first approach is taken, it is suggested that grout be mixed for each base plate separately and poured immediately. Mixing time could be reduced to one minute by use of an electric drill and mixing blade made of steel rod.

If the second approach is taken, grout working time may be increased by use of cold materials, cool foundation, and base plates. This approach involves the use of cold or iced water in the mix to keep the as-mixed temperature of the grout under 70°F (21°C), preferably between 50°F and 55°F (10°C and 13°C).

In either case, the following practices are recommended:

1. Store bags of grout in as cool a place as practicable, but at least in the shade. Avoid exposing the bags to dampness or rain.
2. Give extra attention to saturating the concrete foundation for 24 hours before grouting. Heat and wind cause rapid evaporation; therefore, the concrete should be wet liberally and frequently to prevent drying.

Consider the use of windbreaks and sunshades to maintain saturation.

3. Cool the base plates while saturating the foundation by covering the plates with wet cloths and allowing evaporation to cool them.

2.4.8.2 Cold Weather Grouting

Temperatures below 55°F (13°C) slow the hardening process and keep the grout in a flowable state long enough to permit settlement and bleeding. Although grouting may be successfully accomplished at ambient temperatures as low as 45°F (7°C), the rate of strength gain (hardening) is slow and the required time on-site may be excessive. To minimize the curing time that must be allowed before finally torquing the anchor bolt nuts, it is recommended that the grout, mixing water, and mount base plates be warmed to accelerate the curing process. The following procedure is suggested:

1. Store bags of grout in a sheltered place so that the material will be at least above freezing, but preferably above 45°F (7°C).
2. Measure the temperature of the base plate and foundation by placing a thermometer on the surface and covering it with a piece of dry insulation or dry rags. If the temperature is above 55°F (13°C) minimum, proceed with grouting following the grouting procedures. If the temperature is below 55°F (13°C), warm the base plate and foundation to bring the temperature above the minimum, using the following methods:
 - a) Base plates may be warmed by use of infrared heat lamps or by building a small enclosure around the base plate and introducing heat from a convenient source. Warm the mixing water as necessary to provide mixed grout at a temperature of 60°F (16°C) or above, but avoid use of water hotter than 90°F (32°C).
 - b) After installing grout, maintain the temperature of the in-place grout at 50°F (10°C) or above for a minimum of three hours to ensure adequate grout hardness for final tightening of the anchor bolt nuts.

NOTE

Grout will not harden unless the temperature is maintained above freezing. The minimum temperature is 40°F (4°C).

2.4.8.3 Grouting Procedures

Perform the following procedures to grout the four base plates to the foundation:

1. Wash work surface with water. Keep surface saturated with water for at least 24 hours prior to grouting.

NOTE

Grouting must be completed within 10 minutes after mixing.

2. Pour grout into a five gallon bucket or equivalent mixing container and slowly add water. Stir the mix and add grout or water as required to obtain a good paste.

NOTE

Be sure to mix enough grout to complete each pad at one time. Once the grout begins to set, new grout will not bond to the old grout.

3. Starting on one side of each base plate, use a small strip of wood to work the grout between base plate and foundation. It is important that the grout be worked from one side to the other to prevent air from being trapped under each plate. Once the area under the plate is full of grout, smooth the edges around each plate for best appearance.
4. Immediately after the grout is installed, cover all exposed grout with clean wet rags (do not use burlap). Keep the rags moist for at least two hours.
5. After the grout has cured for a minimum of six hours, turn the leveling screws counterclockwise two to three turns to raise the screw off the bearing surface. Tighten all anchor bolt nuts as follows:
 - Model 8009A mount (1.0-inch diameter anchor bolts) to 240 to 275 ft-lb (325 to 372 Nm).
 - Model 8009AE mount (1.25-inch diameter anchor bolts) to 360 to 440 ft-lb (488 to 596 Nm).

CAUTION

Grout (item 18) must be installed between all base plates and foundation surface to comply with the design loads specified per drawing 519921.

2.4.9 Reflector Mounting

NOTE

The assembly and alignment of reflector must be completed per instructions in paragraph 2.4.6 of this manual before installing antenna hub to mount.

1. Prior to lifting the reflector and hub, swing the elevation actuator over to a horizontal position toward the legs as shown on sheet 8 of drawing 519054. Place a wood block between the elevation actuator assembly and mount as required to prevent damage to actuator assembly.
2. Prior to lifting the reflector and hub, install 0.5 inch eye bolt (item 39) and (Qty 2) support plates (item 19) to hub assembly with 0.5 inch washers and nut as shown on sheet 8 of drawing 519054.
3. Attach three 30 foot nylon lifting straps using three shackles (part no. 521993) to antenna hub as shown in Figure 2-5 for lifting the reflector assembly with a crane. Use short straps, as shown in Figure 2-5, to choke lifting straps near the subreflector mount and spars to prevent side forces on spars during lifting.
4. Lift the assembled reflector and position hub over mount as shown in sheets 8 and 9 of Drawing 519054. Install (Qty 2) elevation pivot pins (item 11), with the tapered end toward the center of mount, through bearing, spacers, and washers.

CAUTION

The pin (item 11) must be installed with the tapered end toward the center of mount. Assembly problems will occur with the elevation Limit Switch and Resolver package installation if the tapered end is installed toward the outside.

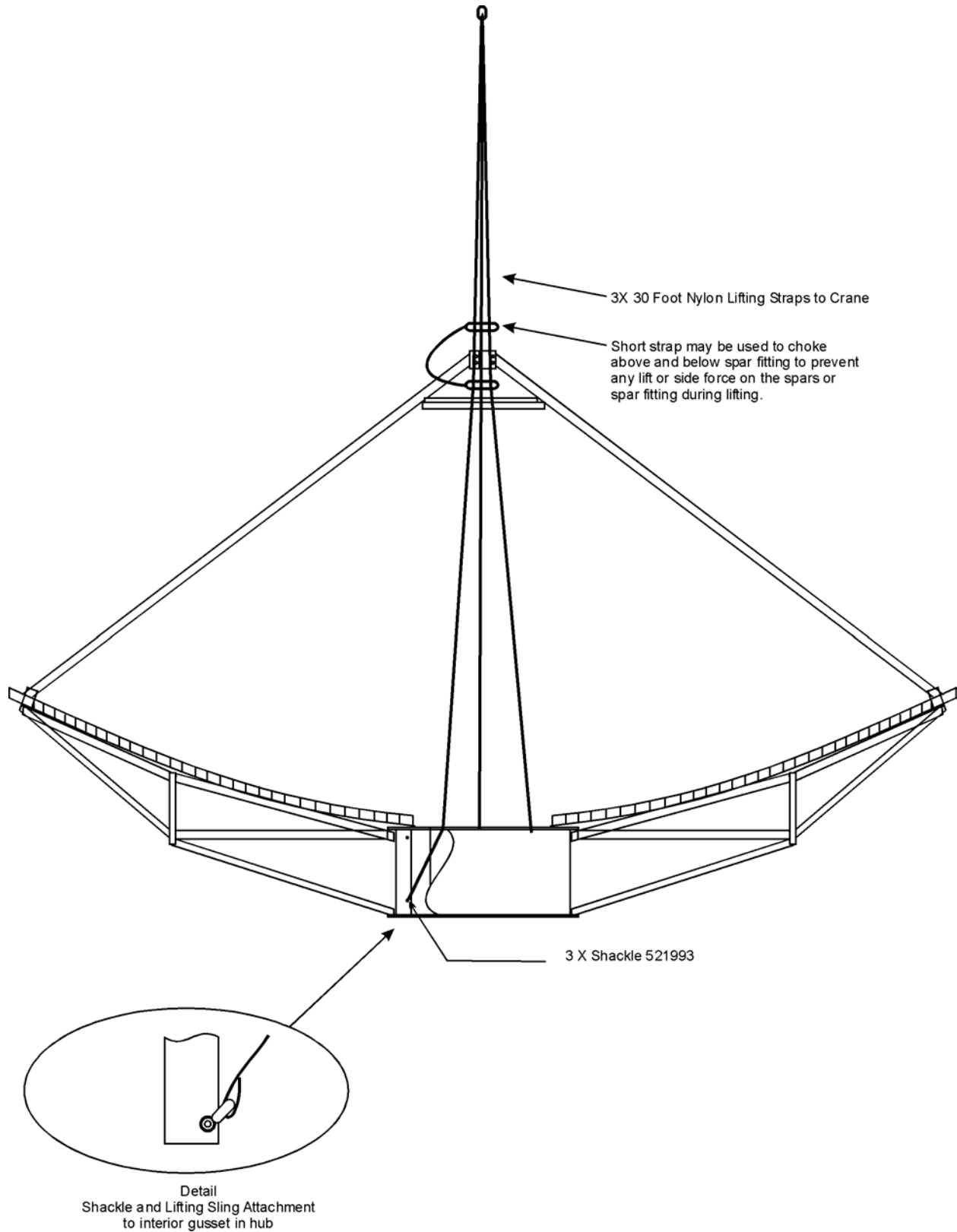

Figure 2-5. Hoisting Reflector and Spars

5. Attach a rope to the elevation actuator protection tube and thread rope through the eye bolt installed in step 2.
6. Swing the elevation jack toward the upper hub pivot and install (Qty 2) pins (item 12) and retainer (item 13) with .25-20 UNC hardware as shown in VIEW D-D sheet 9 of Drawing 519054.
7. Tighten .25 inch hardware to 9 ft-lb (12 Nm).
8. Add grease to grease fitting installed in pins (item 12).
9. Attach (Qty 1) grounding cable (item 17) to hub grounding bracket with .5-inch hardware (items 36, 37 and 38) as shown in view C-C sheet 9 of Drawing 519054. Attach other end of ground cable (item 17) to (Qty 1) grounding bracket (item 16) with 0.5 inch hardware (items 36, 37 and 38).
10. Tighten 0.5 inch hardware to 75 ft-lb (100 Nm).
11. Attach grounding bracket to one of the upper shipping brace holes in the mount with 1.0 inch hardware (items 24, 25 and 35).
12. Attach (Qty 1) grounding cable (item 17) to each leg base plate with 0.5 inch hardware (items 36 and 37) as shown on sheet 8 of Drawing 519054. Attach other end of ground cable to ground lead provided by the installing contractor.

2.4.9.1 Feed Installation

The 9-meter antenna has a large number of feed options therefore each feed is shipped with a set of installation drawings specific to the model. Instructions in this section are general and must be augmented by the installation drawings.

To install feed and associated hardware, a 25-foot extension ladder is required to enter the reflector. During this stage of the assembly, it will be necessary for a person to enter the reflector. Always wear soft sole shoes when working inside the reflector.

WARNING

Never use the crane to lift personnel into the reflector. Serious injury could occur.

CAUTION

Wear only soft-sole shoes or socks while inside the reflector. Only step on the seams between panels where the structure is strongest, never in the middle of a panel.

Perform the following procedure to install and align the feed:

1. Choke two nylon straps around the feed assembly and attach to lifting hook of crane as shown in Figure 2-6.

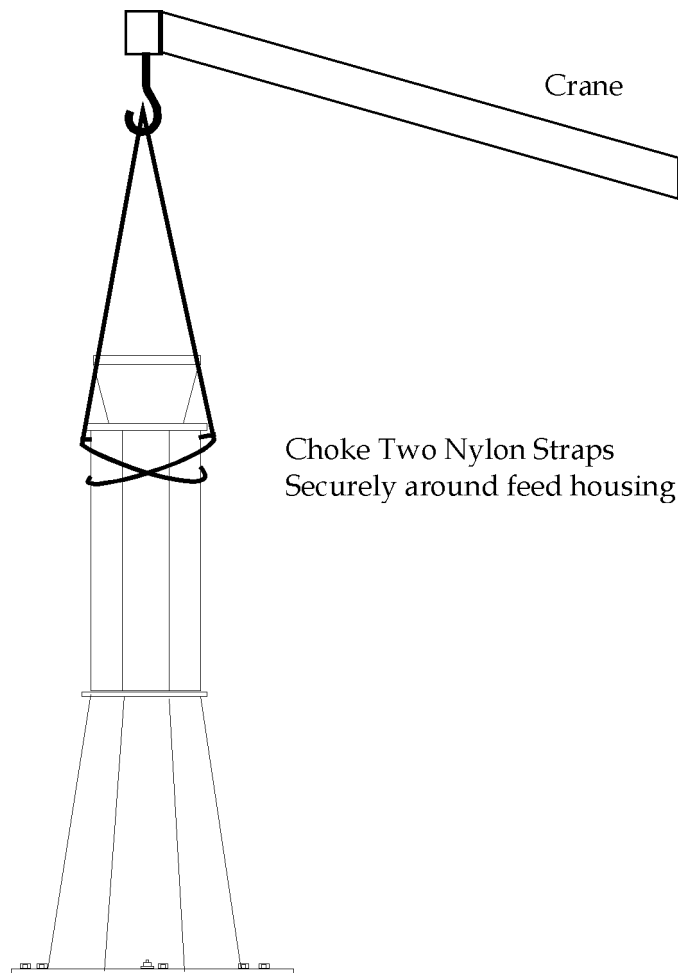

Figure 2-6. Hoisting Feed

2. With one person inside the hub and one person inside the reflector, carefully lift the feed up inside the reflector.
3. Orient feed properly (top of feed toward top of reflector) and attach to polarization drive ring of hub assembly using eight 3/8-16 X 1.75 screws and flat washers.

NOTE

To correct orient the feed refer to the feed installation drawings. With linear feeds it is necessary to orient the feed such that the vertical elements are positioned near the center of the polarization drive. For circular feeds it is only necessary to orient the feed so that waveguide ports can be easily connected to the system waveguides without excessive bending.

2.4.9.2 Installation of Subreflector to Subreflector Mounting Frame

The subreflector adjustment nuts was taped and the subreflector was removed from the mounting frame. (Refer to step 9 of the subreflector alignment procedure on page 2-20.) Reattach subreflector to mounting frame with 3/4-10 nuts and washers as shown in Figure 2-1. Tighten 3/4-10 stainless steel nuts to 130 ft-lb [176 Nm].

2.4.9.3 Transformer Installation Inside Hub

A step down transformer must be installed inside the reflector hub when using 3-phase electrical power other than 208V ac. Refer to Transformer Installation Drawing number 521998 for detailed instructions.

2.4.9.4 Installation of Reflector Hub Cover

Refer to drawing 521988 for hub cover installation. The connector panel (Item 1) must be installed prior to installing the feed waveguide.

2.4.9.5 Installation of Feed Waveguide

Refer to the appropriate Waveguide Installation drawing. An index of drawings is provided in tbd.

Transmit Waveguide Kit	Installation Drawing
C-Band, Standard Power, 2 Port RT Linear	724638-5001
C-Band, Standard Power, 4 Port Linear	521874
C-Band, Standard Power, 4 Port Circular	521876
C-Band, High Power, 4 Port Linear 800 MHz	721953
Ku-Band, Standard Power, 4 Port Linear	521875
DBS-Band, Standard Power, 4 Port Linear	578860

NOTE

The customer interface to the transmit input ports are located at the top of the leg brace of the mount. The interface flange provided with the feed is WR-75 cover grooved flange or CPR-137 grooved flange.

The customer interface to the receive ports is located inside the reflector hub. Systems integrated with LNA packages must be attached to the receive ports and supported to prevent damage to the waveguide flanges. Holes are provided in the rear hub cover for type F or type N connectors with male threads.

2.4.10 Optional Lightning Protection Installation

For best lightning protection, air terminals should always be located at the high point of the antenna and positioned within 10 degrees of true vertical. The procedure for installing the optional lightning protection system on the 9-Meter antenna is as follows:

1. Mount brackets and lightning points on subreflector threaded rod as shown in drawing 571224, sheet 2.
2. Mount brackets and lightning points on highest point of reflector as shown in 571224, sheet 3.
3. Attach aluminum cable to lightning rod clamp on subreflector structure after first stripping cable back 3 inches.
4. Clamp cable to one of the top two spars with cable ties.
5. Route cable to lightning rod clamp on reflector. Strip 3 inches of insulation away and attach cable to clamp.
6. Locate bi-metal clamp on side of hub opposite ladder and attach with copper end oriented toward bottom of reflector as shown in Figure 5-1.
7. Route cable to bi-metal clamp using flat clamps provided to secure cable.
8. Cut off free end of aluminum cable, strip insulation back 3 inches, and attach it to upper end of bi-metal clamp.
9. Strip insulation back 3 inches on copper cable and attach it to lower end of bi-metal clamp.
10. Route copper cable to ground rod or to attachment point for grounding system using flat clamps provided to secure cable. Be sure to provide large service loops at elevation and azimuth pivot joints.

2.4.11 Optional Deicing Installation

All components that are supplied with de-icing are wired to a junction box located in the antenna hub. Run the cables from the components to the junction box and consult the Controls manual supplied with the system for additional installation and check-out procedures.

2.4.12 Electrical Installation

Controller, motors, limit switches, and wiring installation instructions are not contained in this manual. Specific installation instructions will vary depending on the actual controller and type of motors used for the 9M antenna installation. Review the information received with the equipment for specific installation instructions.

CAUTION

While adjusting limit switches, be careful not to let the antenna run into any obstructions. Antenna mounts can be damaged if design limits are exceeded before limit switches are set. Be careful not to allow the TORQUETUBE™ to run into the diagonal braces.

2.4.13 Corrosion Protection

After installation, the mount and antenna should be given a final paint touch-up and an application of corrosion inhibitor at several points.

All painting should be done using a good quality commercial-grade paint that is available in local hardware stores.

1. Apply gloss white paint to any surface of the mount that was paint-damaged during shipping or installation. Paint procedures are in the maintenance section.
2. Spray paint the heads, nuts, and exposed ends of all installed fasteners to seal the joints.

Blank

Chapter 3

Operation

3.1 General

With this elevation-over-azimuth mount, pointing the antenna is accomplished by jogging the antenna in elevation and jogging antenna in azimuth. The azimuth and elevation angles are first established approximately by reference to the indicator provided for each axis, then aligned precisely by peaking on a signal received from a satellite of known position. In addition, the feed polarization and subreflector position are adjusted on the basis of peak received signal.

3.2 Satellite Pointing Procedure

With the feed installed and the electronics operational, use the following procedure for pointing at the desired satellite and peaking on the signal using the motorized earth station antenna.

3.2.1 Elevation Pointing

- a. Place a spirit level on the elevation frame. Adjust the elevation frame to the 90-degree (zenith) position as indicated by the level, and adjust the elevation position indicator to read 90 degrees.
- b. Determine the required elevation angle.
- c. Jog the elevation actuator in the extending direction until the desired angle is reached.

3.2.2 Azimuth Pointing

- a. Determine the required azimuth angle. (The zero mark on the azimuth indicator corresponds to the foundation heading angle.)
- b. Jog the azimuth actuator until the desired angle is reached. Initial pointing of the antenna is now complete.

3.2.3 Signal Peaking Procedure

With the RF components functioning, perform the signal peaking procedure as follows: (The initial setting of the elevation angle should be very nearly correct, having been set to a horizontal reference.)

1. Jog the antenna in azimuth until the satellite signal is peaked.
2. Loosen and calibrate the azimuth angle indicator by adjusting and fixing the pointer at the known azimuth angle of the satellite. Tighten the screws holding the pointer and the indicator plate.
3. If fine adjustment of the elevation angle is required, jog the antenna slightly in the elevation axis to peak on the satellite signal.
4. If required, loosen and calibrate the elevation indicator by adjusting and fixing the pointer at the known elevation angle of the satellite. Tighten the pointer screw.
5. Peak the feed polarization on the signal as follows:
 - a. Rotate feed until the signal peaks.
 - b. Monitor receiver C/N meter or a power meter.
 - c. Rotate the feed counterclockwise until the signal decreases by 1 dB. Record the signal level. Mark a line on the feed mounting plate and a matching line on the hub.
 - d. Rotate the feed clockwise until the meter has passed through the peak and has decreased to the level recorded in Step c. Make a mark on the hub in line with the mark of the feed mounting plate.
 - e. Measure the distance between the marks on the hub. Calculate the mid-point between these marks. Rotate the feed until the mark on the feed mounting plate is aligned with the mid-point.
6. With the antenna peaked on a satellite signal, monitor the receiver C/N meter or a power meter. Loosen the nuts which lock the studs and adjust the subreflector spacing for maximum received signal. Use a scale to verify that the three subreflector adjustment studs are equally spaced from the support clamps. This will verify that the subreflector is not skewed and consequently steering the antenna beam away from the feed. After the maximum received signal is obtained, torque all 3/4-inch hardware to 6 ft-lb. If further adjustment of the subreflector is required, refer to Subreflector Adjustment procedure later in this section.

3.3 Subreflector Adjustment

The following procedure should be used in the event that the antenna performance demonstrates that a subreflector adjustment is necessary. The purpose of the physical measurements to various points on the antenna is to minimize any tilt, or lateral displacement of the subreflector with respect to the main reflector surface and also to position the subreflector to its optimum optical location along the adjustment axis.

1. Ensure all antenna hardware including mount parts are installed and tightened properly prior to making any subreflector adjustment.
2. To establish a reference, measure the distance from the feed window to the subreflector apex as shown in Figure 3-1, distance A.

NOTE

Measurement does not include the tuning plate or spacer.
The feed window should be flat.

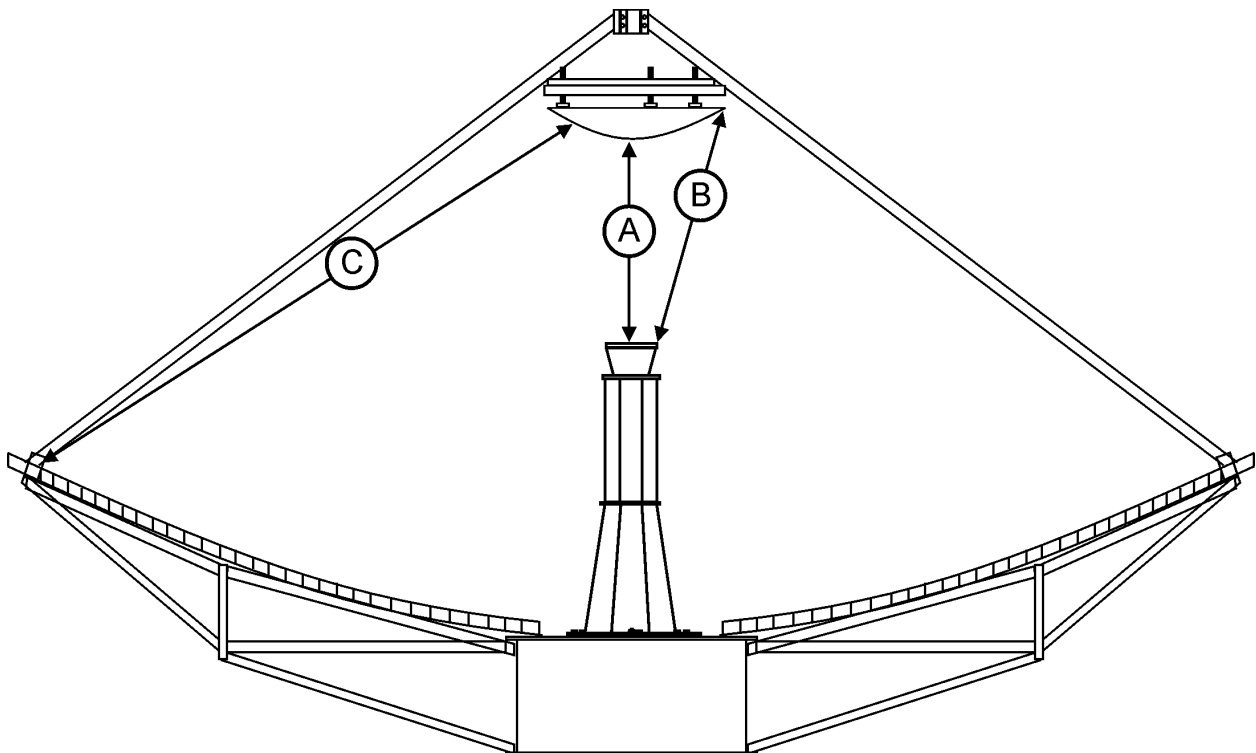

Figure 3-1. Feed, Reflector, and Subreflector Distances

3. If tilt was not adjusted using theodolite, measure the distance between the edge of the subreflector and each corner of the feed horn as shown in Figure 3-1, distance B. Using the subreflector adjustment mechanism, adjust the subreflector until all four distances are equal; this removes any tilt with respect to the feed.
4. If the translation off center was not adjusted using theodolite, measure from the center of the subreflector to each spar pickup point on the dish surface as shown in Figure 3-1, distance C. Any convenient and repeatable measurement point is acceptable as long as it is associated with the machined holes in the spars or the spar tabs. These three measurements should be equal within 0.1-inch nominal. If they are not equal, re-evaluation of the antenna geometry and installation is necessary.
5. If necessary, the subreflector may now be adjusted toward or away from the main dish with the subreflector adjustment mechanism. By adjusting the support studs equally, the subreflector alignment is maintained. Signal level monitoring equipment is necessary to accurately set the subreflector for the highest gain and the deepest radiation pattern nulls. The following equipment or its equivalent is necessary:
 - Spectrum Analyzer
 - Power Meter
 - X-Y Recorder
 - Time Base

The radiation pattern (relative power versus off-axis angle) should be recorded and evaluated for each adjustment of the subreflector. Typical patterns at various subreflector positions which are identified in Figure 3-2 show the changes which take place as the subreflector is moved closer to the optimum focal position.

- a. The first nulls to each side of the main beam will become deeper and eventually bottom out at some level (See Figure 3-2). This level varies depending on the antenna, but should be equal to or greater than 10 dB below the level of the first sidelobe. The deepest null in the H-plane sometimes occurs at a different subreflector position than in the E-plane. In this case, the subreflector should be set at a compromise position between the two planes (i.e., E-plane null depth approximately equals the H-plane null depth).
- b. The signal level of the main beam will also increase as the subreflector is moved closer to the focal position. The power meter can be used to monitor this change. The main signal

level will peak at the antenna focus; however, this change will not be as sensitive as the change in the null depths. Peak main beam signal level and minimum first null depths should coincide for the best subreflector position.

- c. As the subreflector is adjusted toward the optimum focal position, the first sidelobe levels should decrease and remain symmetrical within 2 dB. The minimum sidelobe level will occur approximately at the same subreflector position as the highest signal level and lowest nulls. Should the sidelobes become asymmetrical (greater than 2 dB), Step 3 above should be repeated. It is recommended that after each adjustment of the subreflector, the antenna azimuth and elevation adjustments be re-peaked to compensate for any beam steering due to axial misalignment.

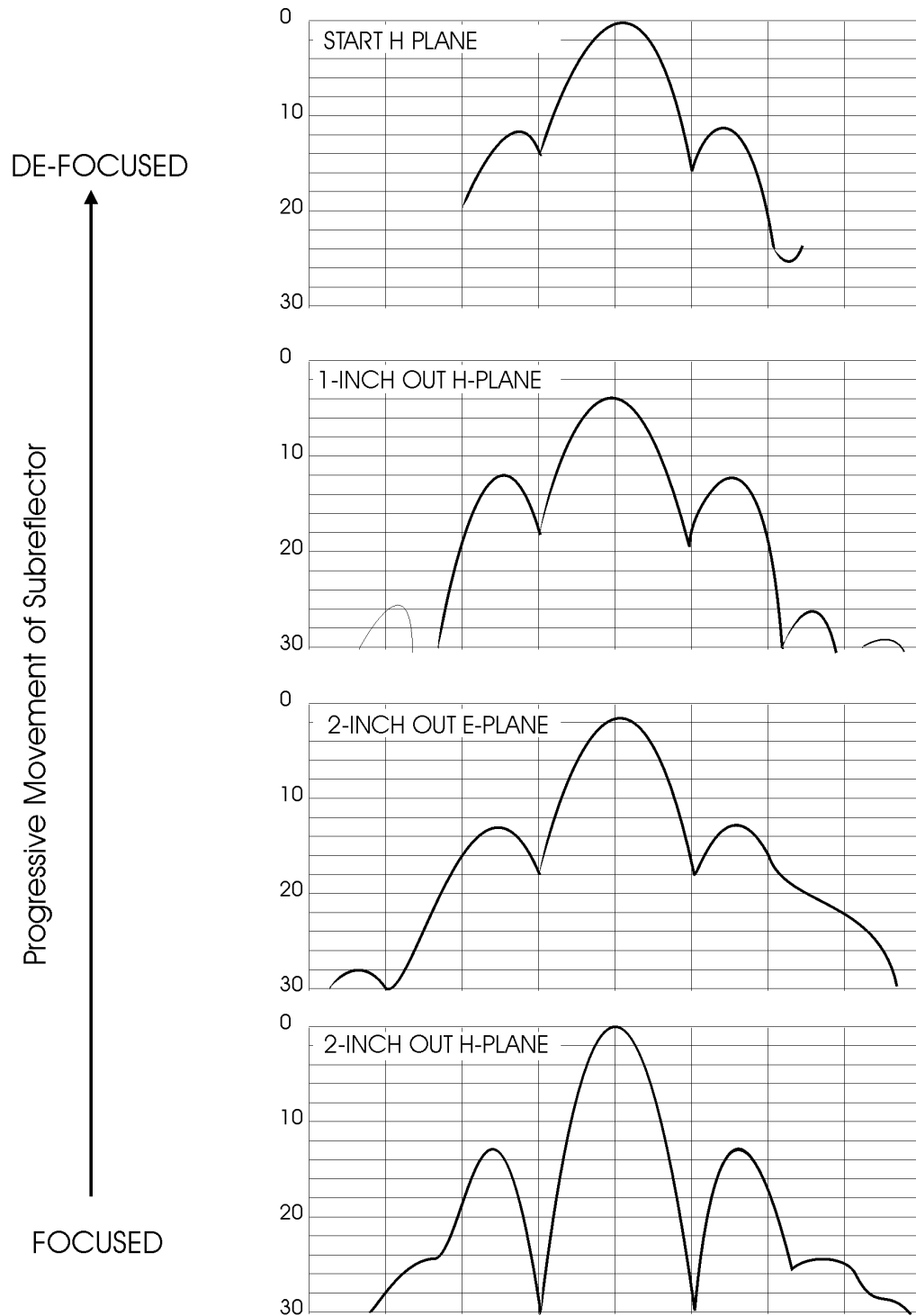

Figure 3-2 Typical Antenna Patterns for Various Subreflector Position

Chapter 4

Maintenance

4.1 General

The 9-Meter Earth Station Antenna is designed for use in many different environmental conditions. Several areas on the antenna require service at various intervals to ensure the proper use and operation. Modification to the suggested service intervals is expected pending customer operation and environmental conditions.

The Model 8009A and the Model 8009AE mount azimuth pivot points are designed with self-lubricated spherical bearings and require no lubrication.

The azimuth and elevation actuators contain a gearbox and a machine screw mechanism which require periodic inspection and application of lubricant as needed.

At no time should substitute parts be used in any repair of this antenna. Use only authorized parts. Any alternations to the antenna not specifically described in this instruction manual and not authorized by ViaSat may void the warranty.

4.2 Periodic Maintenance

The suggested service intervals apply to a typical antenna installation and may vary due to environmental conditions.

4.2.1 Weekly Maintenance

Ensure motorized antennas are driven in azimuth and elevation on a weekly basis. Perform routine inspection and maintenance on waveguides. In areas of heavy snow and ice, mounts should be inspected before movement for excessive accumulation of ice, or damage may result.

4.2.2 Monthly Maintenance

Apply electrical power, as applicable, to azimuth actuator, elevation actuator, and polarization drive assembly. Run each axis for two or three minutes in the normal operating sector. Inspect drain holes in the actuator motors; holes should be open for condensation drainage. Observe brake operation, if applicable.

CAUTION

If it has been some time since electrical power was applied to the actuator motors, go to the antenna, remove all electrical power, manually release the motor brake, and rotate motor shaft. Once it is determined that the brake will release and the shaft will turn freely, then apply electrical power to the motors. Failure to check brake and shaft may result in motor damage.

4.2.3 Bi-Monthly Maintenance

Perform the following procedures at least once every two months.

1. Remove resolver covers, inspect mechanical operation, and check for condensation accumulation. If moisture exists, open all drain holes. Apply a spray-type lubricant (WD-40 or equivalent) to all moving parts. Secure covers.
2. Remove limit switch covers, inspect switch operation, and repair as required. Secure covers.
3. Inspect polarization drive assembly, if applicable, and apply a spray-type lubricant (WD-40 or equivalent) to chain and drive sprocket. Inspect feed chain for correct tension and lubricate if necessary with spray-type lubricant. Ensure that feed rollers are all functional. Inspect flexible transmit waveguide, if applicable, for fatigue. Check limit switch operation. Inspect feed window for damage and replace window as required.
4. Inspect all cotter pins and other devices used as pin retainers. Replace if damaged or corroded; tighten if loose.
5. Inspect mount, reflector, and feed for loose or missing fasteners and replace as required.

4.2.4 Quarterly Maintenance

Perform the following procedures at least once every three months.

1. Inspect azimuth machine screw in accordance with the following procedure:
 - a. Extend actuator to full length.
 - b. Remove boot clamp at end of screw and slide boot back to expose full length of screw.

- c. If the screw is coated with grease and the grease is in good condition, no further action is required.
- d. If the screw is not adequately coated, or if the grease is dry, hard, or contaminated, the lubricant must be renewed. Do not add new grease to old grease on the screw. Clean the screw of old grease using a solvent. Dry the screw with clean cloths. Apply a thin uniform film coating of one of the following low-temperature, clay-based greases.

CAUTION

If one of the following low-temperature greases is not used on the actuator machine screw, damage to the screw or motor could occur.

- Shell Aeroshell #7
 - Mobil Grease #28
 - Mobil SHC 634, in reducer
2. Apply grease to the azimuth and elevation jack housing and gearbox, as required.

CAUTION

When lubricating grease fittings, care must be taken to prevent excessive grease from damaging gearbox seals.

3. Apply low temperature grease to the following moving points (Refer to Figure 4-1):
 - a. Azimuth actuator pivot pin
 - b. Azimuth actuator clevis pin
 - c. Elevation actuator pivot pins.
4. Apply white Rust-Oleum enamel to all mount hardware.
5. Apply spray type rust inhibitor to cavity above spherical bearing for additional bearing protection.
6. Inspect feed window for damage, replace window as required (see Radome Window Replacement Procedure toward the end of this section). If window has moisture, dirt, or other foreign materials present, clean as follows:

- a. Use a clean, lint-free cloth lightly moistened with a diluted solution of mild soap and water to remove foreign material from the radome. Wipe dry using a clean, dry lint-free cloth.
- b. Remove dust from accessible areas.

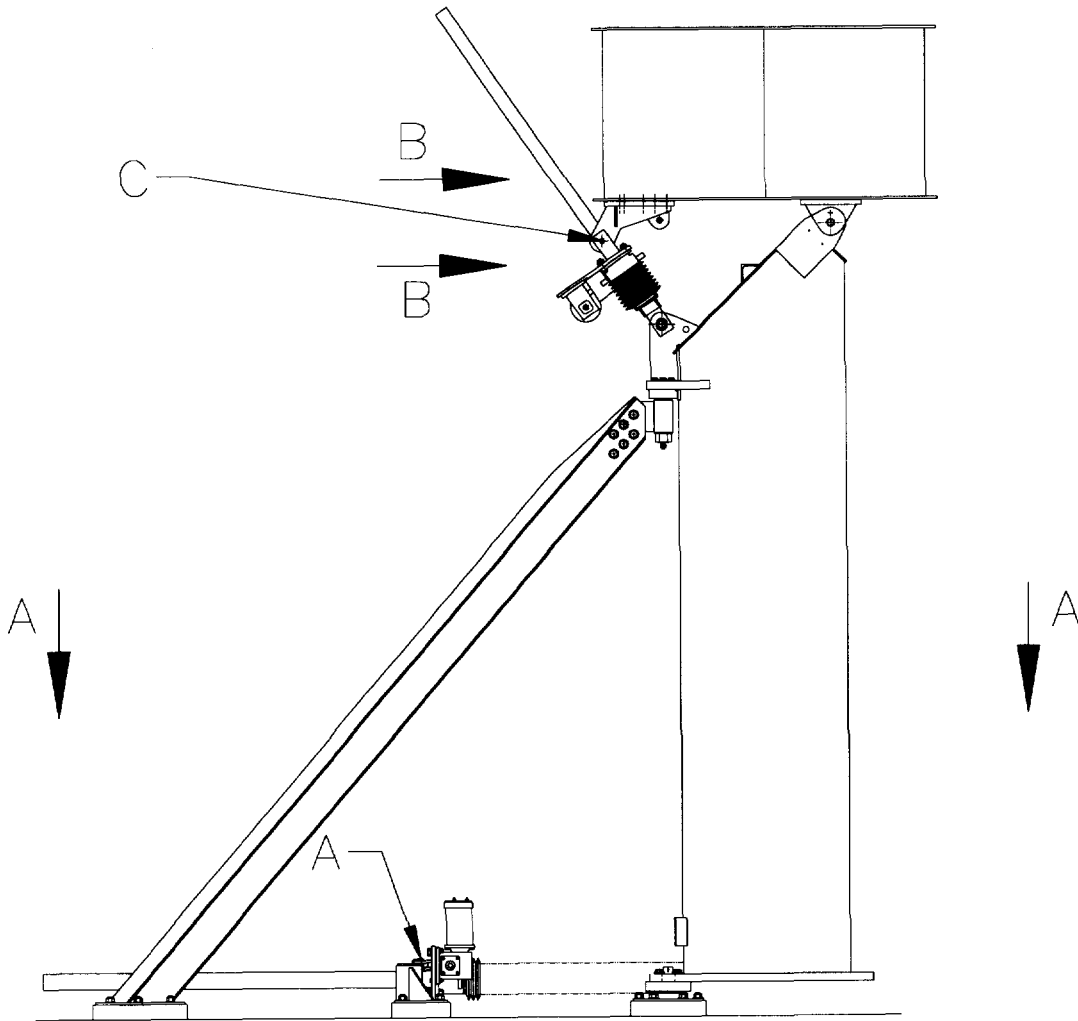

Figure 4-1. Lubrication Points (Sheet 1 of 2)

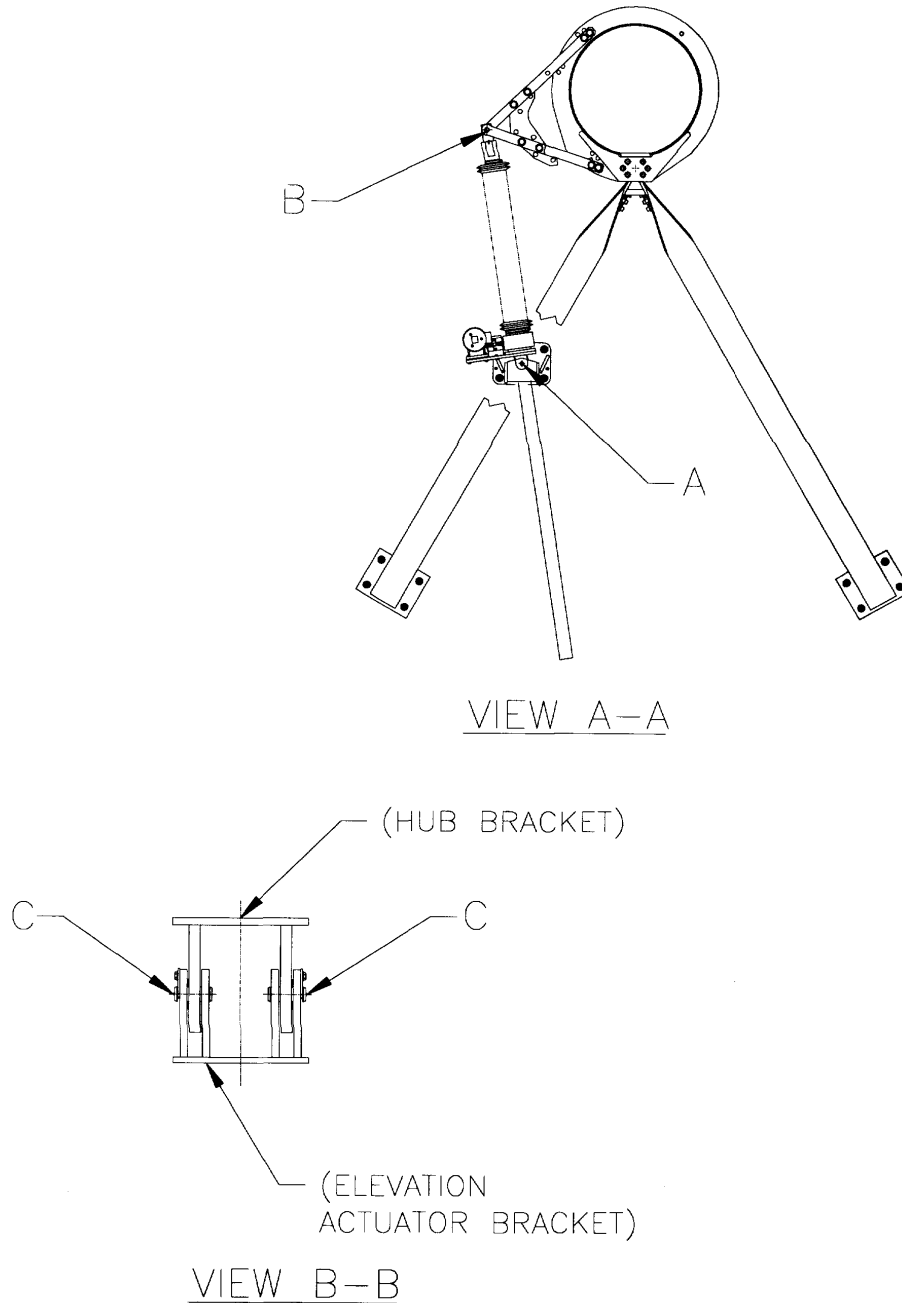

Figure 4-1. Lubrication Points (Sheet 2 of 2)

4.2.5 Yearly Maintenance

Perform the following procedures at least once every year.

1. Inspect foundation pad for structural cracks and repair as required.
2. Replace flexguide every third year.

4.3 Corrosion Protection

Perform the following procedures after completing the installation and every 12 months thereafter.

- a. Evaluate corrosion protection on all anchor bolts, mount hardware, reflector hardware, feed hardware, and subreflector hardware. If protective finish is damaged, clean with a wire brush, remove all rust, and apply a coat of Rust-Oleum (or equivalent) primer and semi-gloss white paint. To improve appearance, finish hardware attached to anodized aluminum parts with Rust-Oleum (or equivalent) semi-gloss gray paint.
- b. Evaluate corrosion protection on surface of mount support tube, mount legs, actuators, resolver brackets, and limit switch brackets. During initial antenna installation, the surface and edges of these parts may receive scratches and will require additional protection. If protective finish is damaged, clean with wire brush, remove all rust, lightly sand with 320 grit (or finer) sandpaper and apply a coat of Rust-Oleum (or equivalent) primer and semi-gloss white paint.
- c. Evaluate corrosion protection on reflector surface, subreflector surface, and spars. If paint is scratched, chipped, beginning to flake, or just wearing thin, lightly sand with 320 grit (or finer) sandpaper and apply a coat of Rust-Oleum (or equivalent) primer and semi-gloss white paint.

4.3.1 Touch-up Painting of Non-Reflective Surfaces

If significant corrosion is found on any part of the antenna mount and actuators, it should be repaired immediately as follows:

1. Material required:
 - a. Sandpaper -320 grit
 - b. Volatile solvent cleaner such as toluene, naphtha or lacquer thinner
 - c. Rust-Oleum gloss white paint (unless a special color was used)
 - Available in Spray cans #2192 or Gallon cans #2766
 - d. Rust-Oleum Primer No. 1573 - for lightly rusted metal
 - e. Rust-Oleum Primer No. 769 - for heavily rusted metal
 - f. Heavy duty detergent

2. Application:
 - a. Wipe damaged portion of finish and surrounding area with solvent. Do not allow solvent to stand on painted areas. Simply wipe surface to remove oily deposits.
 - b. Wash area thoroughly with detergent, rinse thoroughly with water, and allow to dry.
 - c. Sand area to remove rust and "feather" a smooth finish from existing painted surface into areas to be repainted. Be sure to remove all loose paint and rust.
 - d. Heavily rusted metal should be primed by completely covering with Rust-Oleum Primer 769. Lightly rusted or bare metal should be primed by completely covering with Rust-Oleum Primer 1573.
 - e. Primed areas are top-coated with Rust-Oleum gloss white paint.
 - f. The paint application instructions on the respective cans should be followed explicitly.

4.3.2 Touch-Up Painting of Reflective Surfaces

Use the following materials and procedure to repair and retouch scratches and other finish problems such as corrosion and flaking.

1. Material required:
 - a. Solvent - toluene or naphtha
 - b. Detergent - household dishwashing soap
 - c. Thinner - XYLENE
 - d. Sandpaper - 320 grit wet/dry
 - e. Cheesecloth
 - f. Paint Brush - width, 1-inch
 - g. Wash primer - MIL-P-14504
 - h. Zinc chromate - Fed. Spec. TT-P-1757 Composition G
 - i. Top Coat:
Reflective Surfaces - Hi-Reflective Flat White
Harrison, 422W1502, (Flat White)

2. Application:
 - a. Clean entire area around damaged portion with solvent cleaners followed by thorough wash with detergent and water. Rinse well and dry with clean cheesecloth. Do not recoat for 30 minutes or until surface is completely dry.
 - b. Damaged coatings may be repaired by fairing the damaged edges with 320 grit or finer sandpaper. Primer system must be reapplied if damage extends into the bare metal.
 - c. If recoating is to be accomplished in ambient temperatures higher than 100 degrees Fahrenheit, top coating shall be thinned with XYLENE. If coating appears too dry or grainy, add up to 50 percent mineral spirits to slow the evaporation rate.

NOTE

The top coat may be thinned in ratios up to two parts paint to one part thinner.

- d. If repriming is required, apply a thin coat of wash primer and allow to dry for 15 to 30 minutes. Apply a full coat of zinc chromate primer and allow to dry for 2 hours. If surface is not smooth after drying, sand with 320 grit paper lubricated with toluene. Remove dust using a tack cloth (cheesecloth lightly coated with toluene).

4.3.3 Fasteners

The fasteners need to be checked to make sure they are in place and have not loosened. If a fastener is found to be loose, or there is cause to check all the fasteners, use a torque wrench to obtain the proper bolt tension. Torque values are given in Table 2-2 and repeated in Table 4-1 which follows.

NOTE

Galvanized ATM A325 high-strength structural bolts should not be reused. Retightening previously tightened bolts, which have been loosened by the tightening of adjacent bolts, is not considered to be a reuse.

If a fastener should fail and it does not appear to be a result of corrosion, please notify ViaSat as soon as possible.

NOTE

All galvanized fasteners, nominal size 1/2-inch and larger, are high-strength structural fasteners meeting the American Society for Testing and Materials (ASTM) A325 specification. If for some reason one has to be replaced, it is imperative that one be obtained that meets the ASTM A325 specification. If unable to locate, contact the factory for either a suggested source or a replacement.

CAUTION

All structural joints have been designed using ASTM A325 high-strength structural fasteners. If a fastener is substituted that does not meet this specification, failure could occur.

If corrosion of a fastener becomes evident, it should be corrected immediately as follows:

1. Determine extent of corrosion. If base material of fastener is corroded, replace with identical size and type. Refer to drawings parts list for fastener size and type.
2. Remove any corrosion from the fastener (if reused) and surrounding area with a wire brush.
3. Clean parts with toluene or naphtha solvent.
4. After fastener is tightened and paint is dry enough to be recoated, spray fastener head, washers and nut with white paint (or appropriate top coat).

In the case of extensive corrosion of a fastener (i.e., the base material is corroded), replace with identical size and type (SAE Grade 5 steel). Refer to drawing parts list for fastener size and type.

Table 4-1. Torque Values For Antenna Fasteners		
Fastener Size (SAE)	Torque (ft-lb) tolerance $\pm 10\%$	
	Galvanized	Stainless
1/4-20	9 (12 Nm)	6 (8 Nm)
5/16-18	18 (24 Nm)	12 (16 Nm)
3/8-16	30 (40 Nm)	20 (26 Nm)
1/2-13	75 (100 Nm)	45 (60 Nm)
9/16-12	110 (149 Nm)	
5/8-11	150 (203 Nm)	
3/4-10	260 (353 Nm)	130 (176 Nm) (except as noted)
1 Anchor Bolts on Model 8009A mounts	240 to 275 ft - lb (325 to 372 Nm)	
1-1/4 Anchor Bolts on Model 8009AE mounts	360 to 440 ft - lb (488 to 596 Nm)	
1-8 Anchor Bolts	600 (813 Nm)	

NOTE

The required torque value for the foundation anchor bolts may not be accurately achieved by the turn-of-the-nut method. For these bolts, an accurate torque value of 400 to 450 lb-ft (542 to 610 Nm) is required.

Chapter 5

Drawings

5.1 Introduction

This chapter provides assembly drawings, schematic diagrams and parts listings. Drawings are presented in hierarchical order with the highest order drawings shown first.

5.2 Drawing Index

A drawing index is provided in Table 5-1. The drawing number, revision, drawing title and page location of each drawing is included in the index. A dash in the revision column indicates the original release of the drawing.

5.3 Parts Lists

The parts lists in this chapter describe the parts referenced or illustrated by the assembly drawings. Use the information to identify and requisition parts, and as an aid in disassembly/assembly procedures. Parts lists in this chapter are arranged in numerical order by assembly number. When a drawing has a parts list on the drawing, the parts list may not be repeated in this chapter.

Table 5-1. Drawing Index			
Drawing	Rev.	Title	Page
9-Meter Reflector and Hub			
517577	C	ASSY, REFLECTOR,SUBREFL,SPARS, 9M, INSTL	5-3
517055	E	HUB ASSY, MOTORIZED, 208 VOLT, 60 HZ, 9M	5-8
521998	A	INSTL DWG- TRANSFORMER, MTZ PLZN 9/11M	5-11
521988	A	HUB COVER INSTALLATION	5-15
514618	C	POL. DRIVE ASSY,208 VOLT,60 HZ	5-18
523091	-	ASSY,TRANSFORMER-380V TO 220V 9/11 METER	5-21
523092	-	ASSY,TRANSFORMER-415V TO 220V 9/11 METER	5-23
Model 8009A 9-Meter 120° Mount Installation Drawings			
519054	A	INSTALLATION DRAWING, 9M 120° MOUNT/ACTUATORS	5-25
523079	-	DWG. INSTALLATION,LADDDER PLATFORM	5-34
519929	C	ASSY,MOUNT-STD 9M 120 DEG GALV/PAINTED	5-38

Table 5-1. Drawing Index			
Drawing	Rev.	Title	Page
Model 8009AE 120° 9-Meter Extreme Environment 120° Mount Installation Drawings			
517098	A	INSTALLATION DWG 9/11M 1200 MT/ACTUATRS	5-40
477697	D	ASSY, MT, 9M EXTM & 11M (120 DEG)	5-46
Model 8009AE 180° 9-Meter Extreme Environment 180° Mount Installation Drawings			
517097	A	INSTALLATION DWG 9/11M 180° MOUNT/ACTUAT	5-49
476309	D	ASSY, MOUNT-9M EXTM & 11M (180 DEG)	5-55
9-Meter Feed Installation Drawings			
514687	B	INSTL DWG- FEED 8009A-C-4P	5-58
514688	-	DWG FEED INST 8009A K 4P	5-60
517525	A	"DWG, INSTALL,FEED ,9/11 C ,4P,CIRCULAR	5-62
521874	-	"DWG.,INSTL.4P, C LINEAR ,9.0	5-64
521875	A	DWG. INSTALLATION 4P,KU ,LINEAR, 9.0	5-69
550847	A	DWG,INSTL,W/G-4P,C-BAND LINEAR,9M EX/11M	5-75
521876	-	WG INSTL-9M STD C-BAND 4P CIRC FD	5-79
578860	B	WAVEGUIDE INSTL,DWG,WR62,XMT,4P LIN FD	5-83
721953	A	WAVEGUIDE INSTL-9M C-BAND 5KW 4P LINEAR	5-88
724638-5001	-	WAVEGUIDE INSTLN,9M C-BND,RT LINEAR FEED	5-93
Optional Lightning Protection			
517224	A	INSTALLATION,LIGHTENING PROTECTION 9/11	5-98
Actuators			
477503	C	ASSY,ACT,AZ,120 DEG SINGLE SPEED	5-101
477506	C	ACTR SUB SSP 1 HP 208V 60 HZ	5-103
480239	D	ASSY,ACT,AZ,120 DEG VARIABLE SPEED	5-109
482052	E	ASSY,ACT,AZ 180 DEG, VARIABLE SPEED	5-111
511956	B	ASSY,ACT,EL,SINGLE SPEED	5-117
512585	C	ASSY,ACT,EL,VARIABLE SPEED	5-119
517246	D	ACTUATOR ASSY ELEVATION-SINGLE SPEED 9 M	5-121
517562	F	ACTUATOR,ASSY,AZ-SINGLESPEED 7M/9M	5-123
519903	A	PIVOT ASSEMBLY, UPPER AZIMUTH, 9 M	5-125
519911	A	PIVOT ASSEMBLY, LOWER AZIMUTH 9 METER	5-127
521973	B	ACTUATOR ASSY,EL-9M 8862 VARIABLE SPEED	5-129
521974	C	ACTUATOR ASSY,AZ-VARIABLE SPEED 7M/9M	5-132