

UHF IW/DAMA/DASA SATCOM Terminal

ViaSat's RT-1828 and RT-1830 SATCOM IW/DAMA/DASA terminals allow SATCOM users either single channel or multiple channels chassis to meet user requirements.



RT-1828(P)/G

RT-1830 Terminal

The RT-1830 is a single channel terminal that has an extra card slot for an additional four I/O ports.

RT-1828 Four Channel Terminal – Standard 19-Inch Cabinet That Allows Growth

The RT-1828 UHF SATCOM terminal provides from one to four SATCOM channels, and use a VME open architecture that enables easy modification of configurations or selection of only the features required to meet user requirements. When combined with an external 200 Watt power amplifier, LNA/diplexer, and antenna, both the RT-1828(P)/G and RT-1830(P)/S terminals comprise a complete low-cost UHF SATCOM terminal that meets all Legacy Integrated Waveform (IW) and Demand Assigned Multiple Access (DAMA) waveform standards.

Both 19-inch rack mount chassis are equipped with four VME cards per channel: (1) 5/25 kHz IW, DAMA & non-DAMA modem, (2) four port input/output (I/O), (3) UHF upconverter (U/C) and (4) UHF downconverter (D/C). Additional available slots on the RT-1828 series can accommodate up to four independent channels, or alternatively, mix and match variations of other VME-based functions such as additional I/O ports (maximum of 8 per channel).



RT-1830(P)/S

The RT-1828(P)/G version is capable of providing up to four channels and 32 I/O ports per chassis. All ViaSat IW, DAMA, and DASA terminals conform to MIL-STD-188 181B, 181C, 182A, 182B and 183B. A simple software download will upgrade the terminal to other MIL-STD revisions, as they become available.

Line-of-sight (LOS) Options

Both the RT-1828 and RT-1830 are available with VHF/UHF LOS up and down convertors.

Expandable – VME cards provide you many flexible options

The modular design of the RT-18XX Series terminal makes it easy to expand capabilities. For example, adding a second I/O card can yield up to eight user I/O ports.

Open VME Architecture – For modular growth

The VME architecture of the RT-18XX promotes modularity and growth of the terminal. You can add additional channels by adding VME modules. The open architecture enables low-cost growth paths for embedded UHF LOS mode, telephony interface, and other features and functions.

ViaSat Control Indicator – Or use other control options

The RT-18XX Series of terminals may be controlled by a variety of means including the ViaSat C-12480/U Control Indicator, or serial asynchronous interface (PC), or an Ethernet interface. ViaSat's Network Terminal Control (VNTC) software is also available to control the terminal.

SPECIFICATIONS

GENERAL CHARACTERISTICS

Operating Modes	5 kHz DAMA (bps)	Non-DAMA (kbps)	25 kHz DAMA (bps)
User I/O Rate	75, 300, 600, 1200, 2400	1.2, 2.4, 4.8, 7.2, 8.0, 9.6, 16.0, 28.8, 32.0, 38.4, 48.0, 56.0	75, 300, 600, 1,200, 2,400, 4,800, 16,000
Burst Rate	600, 800, 1200, 2400, 3000 sps	N/A	9.6, 19.2, 32 ksps
Modulation	SOQPSK	SBPSK, FSK, CPM	BPSK, DEQPSK
Coding	R1/2, 3/4, 7/8	RS	R1/2, 3/4
I/O Ports	2	1	8
Control	Ethernet MIL-STD-188-114 • C-12480/U Control Indicator • PC or Workstation		
IW	All mandatory and optional rates and modes supported		
Key Fill (All)	KYK-13, KYX-15, KOI-18, AN/CYZ-10		

PERFORMANCE CHARACTERISTICS

Frequency Offset	Acquisition with up to ± 1200 Hz offset
Doppler Correction	Uplink for operation with narrow bandwidth acquisition modems (e.g., TD-1271)
BER	Within 1.5 dB of theory, Typically < 5 sec.

RT-1828(P)/G AND RT-1830(P)/S MIL-STD CAPABILITIES

188-183: Yes / (AC/DC)	188-181C: Yes
188-181B: Yes	188-182B: Pending
188-182A: Yes	188-183B: Yes
Encrypted O/W: Yes	188-185: Yes

INTERFACES

Data	MIL-STD-188-114 balanced or unbalanced; synchronous data, clock and control
Compatible COMSEC	AN/CYZ-10; ANDVT Minterm, Tacterm, Airterm; KG-84; and others
Frequency Ref, Ext	1, 5 or 10 MHz Standard, 0 ± 10 dB
Frequency Ref, Int	10 MHz, 1ppm
LOS AM/FM	TX, RX: 600 ohms, balanced, 300 to 3500 Hz frequency response
UHF	RX: 243 to 270 MHz, 50 ohms, VSWR $< 2.5:1$ TX: 292 to 318 MHz, 50 ohms, VSWR $< 2.5:1$
Remote Control	Ethernet or MIL-STD-188-114 asynchronous with interface to RS-422, RS-423 and RS-232
Power Source	120 VAC, 50/60 Hz or 240 VAC, 50 Hz

PHYSICAL CHARACTERISTICS

Dimensions (HD)	15.25 x 24 inches
Volume	< 7200 in ³
Weight	< 100 lb

ENVIRONMENTAL/EMI

Operation Temperature	0°C to 50°C
Altitude	0 to 15,000 ft
Humidity	95%
Cooling	Convection cooled
EMI	MIL-STD-461D

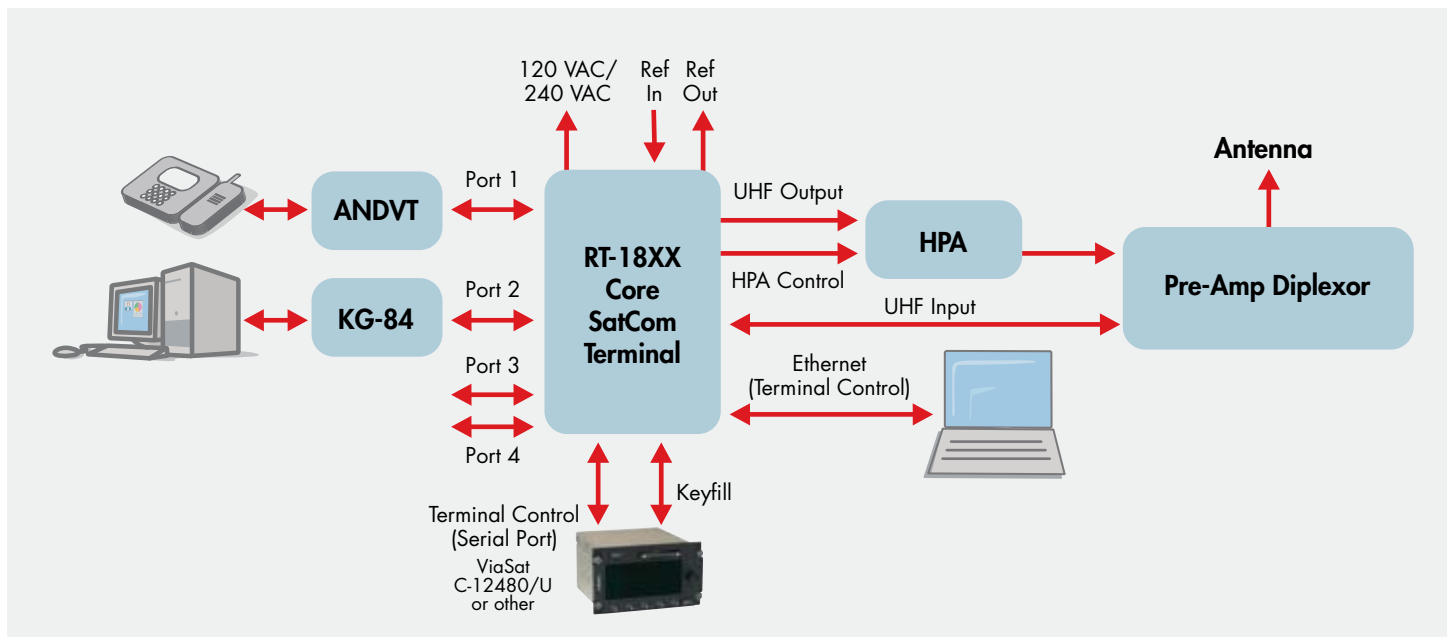

ViaSat, Inc.
 6155 El Camino Real
 Carlsbad, CA 92009 USA

Sales: 760.476.2472
Fax: 760.929.3968
Technical: 760.476.2457
Email: gov.satcom@viasat.com
www.viasat.com

